

GL117



The pathology workstation is an economical space saving unit that comes with all required features for any grossing procedure. We also carry a complete listing of optional accessories to fulfill anyone's personal needs.

STANDARD DESIGN FEATURES

Length:48 in./121 cm.
 Length:60 in./152 cm.
 Height/Overall:51 in./129 cm.
 Width:30 in./76 cm.

- Available in two sizes: 48 in./121 cm. long and 60 in./152 cm. long
- All stainless steel construction of the entire work area and all exterior closure panels.
- Exhaust duct for connection to building ventilation system
- Hot and cold water mixing faucet with gooseneck spout and wrist blade handles

- Spray hose assembly with hand control
- Heavy-duty commercial waste disposer, 1/2 hp and switch
- Dissecting area rinse to provide a constant flow of water to work area
- Specimen shelf, welded heavy gauge stainless steel
- Removable stainless steel dissecting grid plates located over the drain trough
- Fluorescent, vapor-proof light with switch
- Polyethylene dissecting board (Photo Blue)
- GFCI duplex receptacle w/waterproof cover
- Dissecting area is sloped toward sink basin for rapid and positive drainage
- Heavy-gauge polished stainless steel leg assembly with welded cross rails to handle heavy-duty usage
- Wheel chair accessible

All measurements in inches/centimeters

We also carry Biopsy Bags



**Call for more information
(800) 410-0100**

**MODEL GL117
PATHOLOGY WORKSTATION w/REAR EXHAUST**



Optional Accessories

- Heavy-duty commercial disposer (3/4 hp, 1 hp, 2 hp)
- (3) sided rinse assembly
- Eyewash drench assembly
- Eyewash assembly, faucet mounted
- CO2 valves/vacuum valves/compressed air valves
- Hands free soap dispensers
- Specimen rinse
- Plexiglass splash shield
- Utility drawer
- Pull out writing platform
- Utility drawer/pull out writing platform combo
- Digital platform scale, 4 lbs./2 kg capacity, economy or premium grades available
- Removable measuring rule
- Dissection boards
- Computer monitor and keyboard stand premium or standard grades
- Digital voice recorder
- Articulating arm fluorescent light w/magnifier
- Articulating arm examination light w/magnifier
- Flex arm incandescent light w/magnifier
- Flex arm halogen lights
- Seismic Anchors

Options based on available space

When planning an order, we will assist you in selecting options to complete your system. Please feel free to contact us.

Custom layout and designs are available.

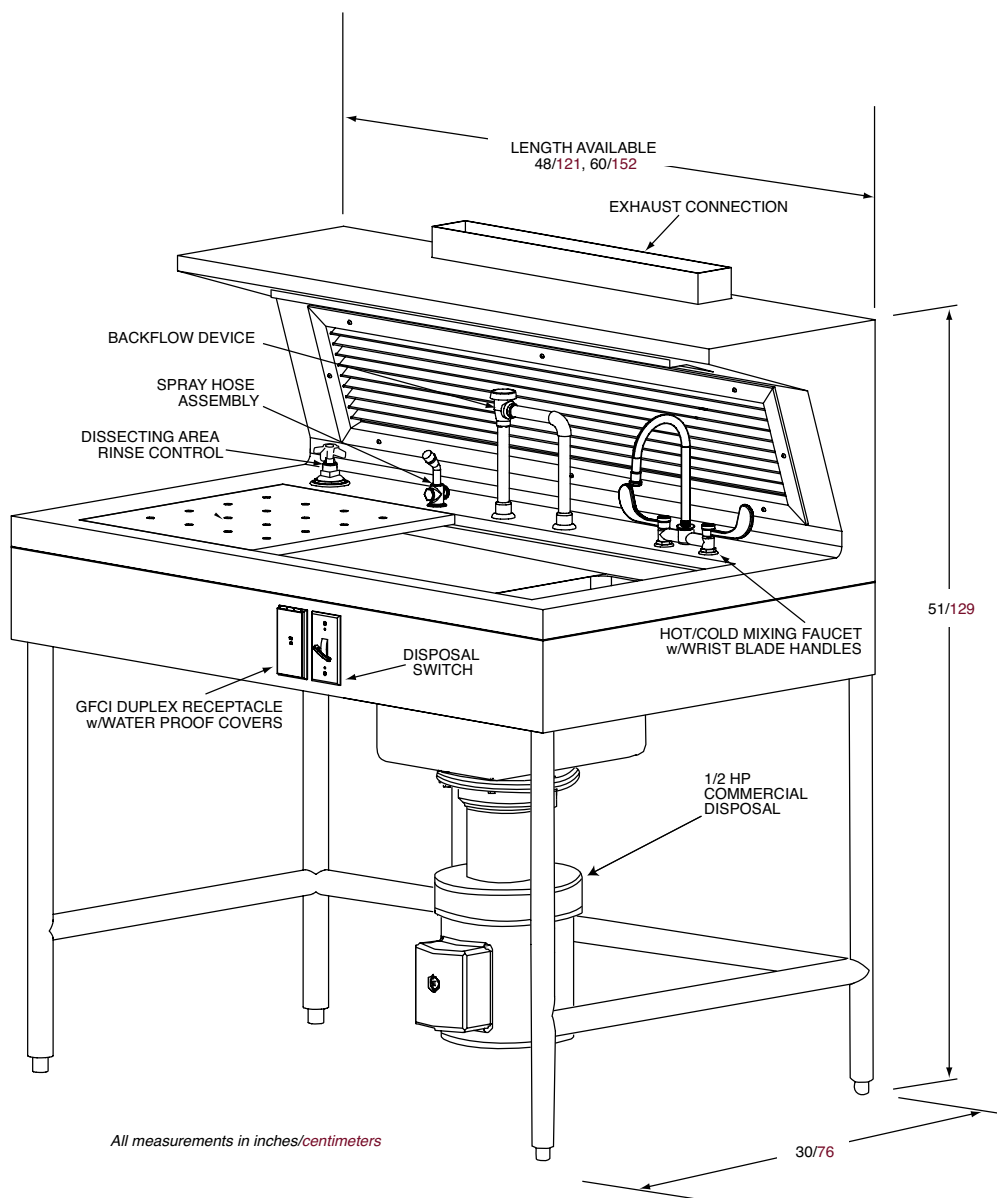

PATHOLOGY GROSSING STATIONS



Economy Monitor & Keyboard Stand



Premium Monitor and Keyboard Stand



Digital Voice Recorder



Camera Mount



Video Camera Mount



Cassette Holders



Removable Measuring Rule



Microphone on Flex Arm



Stainless Steel Storage Containers

Economy Monitor & Keyboard Stand

The arm allows the full articulation of the LCD. This stand folds up and extends from the mount to the LCD, having two articulating arms. Two handles next to the monitor tighten the monitor into position. The monitor can be adjusted vertically on two stainless steel rails.

Premium Monitor & Keyboard Stand

This is a compact LCD mount. The monitor mount has close to 75° tilt (depending on the monitor) at the pivoting joint. A 100 mm VESA interface plate is provided. This model mounts to a wall track. It has an 11" arm for the LCD and a 20" double arm for the keyboard tray. Machined out of billet aluminum, this unit is powder coated gloss white for a durable, lasting finish.

Digital Voice Recorder

Audio recorder is stacked with premium features and enhanced DSS Player Pro Dictation software for outstanding performance. It's designed inside and out to provide you with all the conveniences you need for easy, flexible & productive dictation.

Camera Mount

Securely holds camera, adjustable ball and socket system, not only lets you put your camera right where you want it, but allows for ease of adjustment and better coverage.

Video Camera Mount

Hold video camera securely, adjustable ball-and-socket system, not only lets you put your video camera right where you want it, but allows for ease of adjustment and better coverage.

Cassette Holders

Conveniently holds cassettes within arms reach and removable boxes mount to rail on front of unit. Set of (3) boxes provided.

Removable Measuring Rule

Provides a device for ruling a portion of the subject, the ruler includes a scale in centimeters and inches.

Microphone on Flex Arm

Easy-to-adjust, rugged, small-diameter, alternating gooseneck provides a steep low frequency attenuation to improve sound pickup without affecting voice quality, comes with 48V Phantom Power Supply, Integral 3-pin XLRM-type (connection).

Stainless Steel Storage Containers

Containers set in a No. 4 finish, available in (2) sizes and are removable.

GROSSING STATION ACCESSORIES

411 North Aerojet Avenue
Azusa, CA 91702
Tel (800) 410-0100 • (626) 334-1471
Fax (626) 334-1704
www.mortechmfg.com

ISO 9001: 2008 CERTIFIED COMPANY



Heavy Duty Commercial Disposer



Full Plexiglass Enclosure



Digital Scales



Replacement Filters



Form Holder

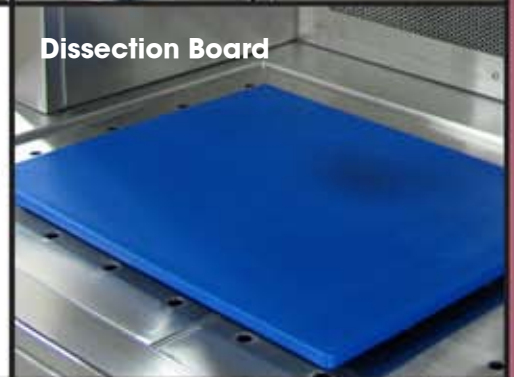

Dissection Board



Sharps Disposal Container



Magnetic Instrument Holder



Specimen Rinse

Heavy Duty Commercial Disposer
(1/2 hp, 3/4 hp, 1 hp, 2 hp) It delivers superior performance, quiet operation, maximum energy efficiency and long service life, corrosion resistant stainless steel construction

Replacement Filters Model GL112
Activated filter for odorous and formaldehyde fumes

Sharps Disposal Container
Provides a cost-effective solution for disposal of needles, syringes, and lancets, as well as other types of sharps and small quantities of medical waste. It is a safe and easy alternative to large volume waste handling

Full Plexiglass Enclosure
Covers and protects the working area for sanitary purpose, constructed of .5 in./1 cm. plexiglass, greatly increases fume control

Form Holder
Sturdy construction and can be mounted to store documents away from any fluids and risk of damage, (2) provided standard

Magnetic Instrument Holder
conveniently store and organize your most commonly used instruments within arms reach

Dissection Instrument
Providing you with the highest quality made dissection instruments. Our instrument range from the finest tipped Vannas spring scissors and forceps, to Gluck Rib Shears and Super Cut Scissors, ensuring that we meet all of our customers' instrument needs, regardless of application

Economy Grade Scale or Digital Platform Scale (2 Kg)
Compact scales are lightweight, portable and perfectly suited for use in laboratory and education applications

Dissection Board
Polypropylene construction to help preserve dissecting knives and scalpels when in use (Photo Blue and white)

Specimen Rinse
Single mesh fine with a plastic handle includes stainless holder that fits over sink

PATHOLOGY GROSSING STATIONS

Flex Arm Halogen Light



Fluorescent Magnifier Light

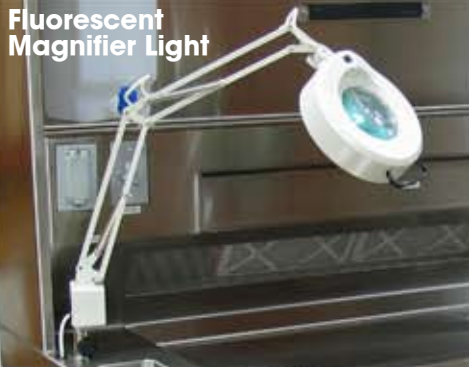

Spray Hose Assembly



Flex Arm Magnifier Light



Magnifying Examination Light



Hot and Cold Foot Valve



Exam Light



Compressed Air Valves CO2 Valves, Vacuum Valves



EyeWash Drench Assembly



Flex Arm Halogen Lights

Produces over two times more light output than a 100 watt bulb while remaining cool, 3 in./7 cm. x 3 in./7 cm. filter and a 25 in./63 cm. flexible steel gooseneck delivers light exactly where needed

Flex Arm Magnifier Light

This rugged yet stylish light is mounted on the station and will provide direct focused light over work area with a flexible gooseneck arm, this 100 watt incandescent light is available with a magnifiers and up to two units can be placed on each station, practical lighting for any task

Exam Light

Delivers best-in-class intensity, color temperature and CRI, all on a highly positionable arm, Delivering higher illumination in a limited area, uses halogen technology for maximum light output and color rendering, a dual lens optical system collects and concentrates the light in a precise beam, LED versions are available

Fluorescent, Magnifier Light-3X

Flexible spring-balanced arm, 3-diopter supplied with 22-watt Circline fluorescent tube, plastic splash guard, convenience outlet in base, 3-conductor cord, and handle on shade permits easy positioning

Magnifying Examination Light

Its unique, powerful 3.5 diopter magnifier is superior in both form and function. Plus, two independent fluorescent light bulbs offer 30% more intensity and enhance optical performance for your procedures.

Valves

Ruggedly constructed, designed for setting volume and pressure to isolate flow on your grossing station

Spray Hose Assembly

Easy grip assembly with flexible hose, conveniently placed for easy spray cleaning of debris

Hot and Cold Foot Valve

Sturdy constructed foot pedal to help temper water and keep your hands free while working

Eyewash Drench Assembly

Often times it is beneficial to have a hose unit to assist in the irrigation process. The drench head can be easily activated with integral squeeze lever, providing a maximum coverage area for the body with its soft flowing streams of water. Unit is conveniently mounted using wall clips keeping the emergency equipment held firmly against the wall

GROSSING STATION ACCESSORIES

411 North Aerojet Avenue
Azusa, CA 91702
Tel (800) 410-0100 • (626) 334-1471
Fax (626) 334-1704
www.mortechmfg.com

ISO 9001: 2008 CERTIFIED COMPANY



Self Contained Ventilation Assembly



Stainless Steel C-Fold Paper Towel Holder

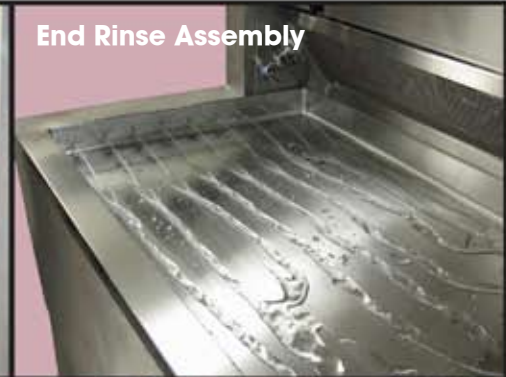

End Rinse Assembly



Utility Drawer



Hands Free Controls

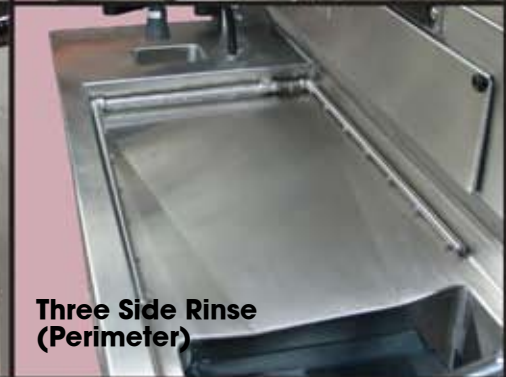

Three Side Rinse (Perimeter)



Utility Drawer/Pull Out Writing Platform Combo



Ventilated Trash Container



Stainless Steel Shelving

Self Contained Ventilation Assembly

Consisting of 3 blowers with filters to clean and safely recycle air within your work area

Utility Drawer

Constructed of all stainless steel, this drawer is ideal for additional storage of utensils, office supplies or personal items

Pull Out Writing Platform

Sturdy stainless steel construction provides a reliable smooth surface for writing and conveniently hides away

Utility Drawer/Pull Out Writing Platform Combo

Conveniently combine both accessories in one, a writing platform then lift and you have a storage drawer

Stainless Steel C-Fold Paper Towel Holder

Surface mounted towel dispenser fabricated of type 304, 22 gauge stainless steel with exposed surfaces in satin finish, tumbler lock to secure hinged front panel and towel dispenser capacity of 400 C-fold or 525 multifold paper towel

Hands Free Controls

Available for easy On/Off control of the table rinse, mixing faucet, waste disposal, hot and cold water

Ventilated Trash Container

Made of stainless steel, can be provided for waste disposal, top lid removes to hold a 13 gallon trash liner and 1.5 in./3 cm. duct attaches to station exhaust system for fume removal, Container size: 13" X 13" x 29"

End Rinse Assembly

Allows debris to flow toward the sink basin. Unit can be manually controlled by valve or is hands free controlled

Three Side Rinse

Provides a constant flow of water to the work surface to wash debris toward the sink basin. Unit can be manually controlled by valve or is hands free controlled

Stainless Steel Shelving

All stainless steel construction adds additional space for storage placement of accessories, adjustable and fixed, standard size adjustable shelving is 12 in. x 7 in,

PATHOLOGY GROSSING STATIONS

Seismic Anchors



LED Lighting



Formalin Faucet



Hands Free Soap Dispenser



Eyewash Assemblies



Dry Erase Board



Carboy Formalin Container



Glove Box Holders



CPU Wall Mount



Seismic Anchors

Securely holds your grossing station in place with sturdy gauge floor mount brackets, Engineered seismic calculations available at an additional cost

Hands Free Soap Dispensers

High-efficiency pump mechanism provides quick and precise dispensing. Easy-to-use buttons control and the wide opening makes refills fast, easy and mess-free, (2) models available-Deck and Wall Mount

Carboy Formalin Container

Space-saving rectangular shape, excellent chemical resistance, a good choice for storing and dispensing stock solutions

Elevating Capabilities

Elevating comes standard on select items, it is available on additional models (optional) Call Mortech for availability and recommendations, adjustable height will accommodate the operator with ergonomic area for sitting

LED Light

Long lasting efficient way of lighting any workstation, clean and elegant design Energy Star Certification for year-round energy savings and is also ETL classified for safety

Eyewash Assemblies

Convenient, compact, medically superior flipdown way to remove eye contaminants, autoflow eyewash wall mounting, spray heads swing down from storage to operational position, activating water flow

Faucet mounted model inverted water flow pattern washes contaminants away from the eyes, assuring superior eye protection, Built-in thermostat safety valve automatically shuts off eye wash flow if water temperature reaches 100°F (37°C) or higher, Allows normal faucet function when properly installed

Glove Box Holders

Stainless steel support to hold latex and nitrile glove boxes, holders come in a side load and top load model

Formalin Dispensing & Collecting System

Dispensing assemblies for formalin system. There is no metal contamination to PVC parts, table or wall mount available

Dry Erase Board

Provides easy dry-erase writing for meetings, brainstorming and discussions, strong fiberboard and frame resist warping and bending

CPU Wall Mount

Designed for form factor CPU's from 4.6 to 8" wide, these units are constructed from heavy-duty aluminum, with neoprene padding to protect your CPU as it is clamped securely into the mount

GROSSING STATION ACCESSORIES

411 North Aerojet Avenue
Azusa, CA 91702
Tel (800) 410-0100 • (626) 334-1471
Fax (626) 334-1704
www.mortechmfg.com

ISO 9001: 2008 CERTIFIED COMPANY



**FORMALIN CABINET
(STAND ALONE SYSTEM)**

**OPTIONAL BACKDRAFT
& BELOW CABINET VENTILATION**



CHEMICAL DISPENSING SYSTEM

Call for more information on designing your system.

FORMALIN CABINET

We carry a line of fully customizable stand alone formalin cabinets. Perfect addition for the growing facilities need.

STANDARD DESIGN FEATURES

- Stainless steel cabinet to encase the system
- (Optional) backdraft and below cabinet ventilation

STANDARD DESIGN FEATURES

- Systems can be placed in an alternative location to reduce fumes.
- Pump(s) to draw fluid from multiple formalin solution barrel(s)
- Peristaltic drive and pump option
- Air compressor driven system option
- Adjustable pressure controls
- System safety alarms for fluid spills, low pressure system, malfunction
- Electrical panel w/easy operating controls and indicator lights
- Pump one or pump two selector switch
- Includes containment platform with drain pan and leak sensor
- Formalin and drums provided by facility

FORMALIN DISPENSING & COLLECTING SYSTEMS

Mortech can design a system to fit any facility, laboratory, and grossing station. A formalin system will consist of an ability to store a supply (Formalin Reservoir or a Carboy Dispenser and formalin solution barrel), then be released from a dispensing spigot while entering into a collecting sink and finally drains into a waste reservoir.

CHEMICAL DISPENSING SYSTEM

Systems can be provided for a single or multiple workstations. The chemical dispensing system is a larger scale formalin dispensing/distribution station designed to provide multiple workstations with a buffered formalin solution. The dispensing system draws a formalin solution from a 30 to 55 gallon drums to formalin spigots