

Signature

SLIDE PRINTER



PRIMERA

© 2012 All rights reserved

For the most recent version of this manual please visit

<http://www.primera.com/manuals.html>

USER'S MANUAL

Notices: The information in this document is subject to change without notice. NO WARRANTY OF ANY KIND IS MADE WITH REGARD TO THIS MATERIAL, INCLUDING, BUT NOT LIMITED TO, THE IMPLIED WARRANTIES OF MERCHANTABILITY AND FITNESS FOR A PARTICULAR PURPOSE. No liability is assumed for errors contained herein or for incidental or consequential damages in connection with the furnishing, performance, or use of this material. This document contains proprietary information that is protected by copyright. All rights are reserved. No part of this document may be photocopied, reproduced, or translated into another language without prior written consent.

Trademark Acknowledgments: Windows is a registered trademark of Microsoft Corporation. All other trademarks are the property of their respective owners.

Printing History

Edition 1.1, #062812, Copyright 2012, All rights reserved.

FCC Compliance Statement: This device complies with part 15 of the FCC rules. Operation is subject to the following two conditions: (1) this device may not cause harmful interference, and (2) this device must accept any interference received, including interference that may cause undesired operation.

For Users in the United States: This product is intended to be supplied by a UL listed Direct Plug-In Power Supply marked "Class 2" or a UL listed ITE Power Supply marked "LPS" with output rated 12VDC, 4.5A or higher. This equipment has been tested and found to comply with the limits for a Class A digital device, pursuant to Part 15 of the FCC Rules. In a domestic environment this product may cause radio interference, in which case the user may be required to take adequate measures. This equipment generates, uses, and can radiate radio frequency energy and, if not installed and used in accordance with the instructions, may cause harmful interference to radio communications. However, there is no guarantee that interference will not occur in a particular installation. If this equipment does cause harmful interference to radio or television reception, which can be determined by turning the equipment off and on, the user is encouraged to try to correct the interference by one or more of the following measures:

- Re-orient or relocate the receiving antenna.
- Increase the separation between the equipment and receiver.
- Connect the equipment into an outlet on a circuit different from that to which the receiver is connected.
- Consult the dealer or an experienced radio/TV technician for help. Use of shielded cables is required to comply with the Class A limits of Part 15 of the FCC Rules. You are cautioned that any changes or modifications not expressly approved in this manual could void your authority to operate and/or obtain warranty service for this equipment.

For Users in Canada: This digital apparatus does not exceed the Class A limits for radio noise for digital apparatus set out on the Radio Interference Regulations of the Canadian Department of Communications. Le présent appareil numérique n'émet pas de bruits radio électriques dépassant les limites applicables aux appareils numériques de la classe A prescrites dans le Règlement sur le brouillage radioélectrique édicté par le ministère des Communications du Canada.

CAUTION!

TO PREVENT FIRE OR SHOCK HAZARD, DO NOT EXPOSE THE UNIT TO RAIN OR MOISTURE. TO REDUCE THE RISK OF ELECTRIC SHOCK, DO NOT REMOVE EXTERIOR PANELS. NO USER-SERVICEABLE PARTS INSIDE. REFER SERVICING TO QUALIFIED SERVICE PERSONNEL. OPERATE THE UNIT WITH ONLY THE PROPER ELECTRICAL SPECIFICATIONS AS LABELED ON THE PRINTER AND AC ADAPTER.

CAUTION!

**THIS PRODUCT CONTAINS A LASER DIODE OF A HIGHER CLASS THAN 1. TO ENSURE CONTINUED SAFETY, DO NOT REMOVE ANY COVERS OR ATTEMPT TO GAIN ACCESS TO THE INSIDE OF THIS PRODUCT. REFER ALL SERVICING TO QUALIFIED PERSONNEL. THE FOLLOWING LABEL APPEARS INSIDE YOUR UNIT:
CLASS 1 LASER PRODUCT LASER KLASSE 1**

CAUTION!

USE OF CONTROLS OR ADJUSTMENTS OR PERFORMANCE OF PROCEDURES OTHER THAN THOSE SPECIFIED HEREIN MAY RESULT IN HAZARDOUS RADIATION.

Table of Contents

Section 1: Getting Started	1
A. Choosing a Good Location.....	1
B. Unpacking and Inspection.....	2
C. Identifying the Parts.....	3
D. Slide Specifications.....	5
E. Connect Power.....	6
F. Load a Ribbon.....	7
G. Load a Slide Cartridge.....	10
H. Install the Printer Driver.....	13
Section 2: Printing Slides	14
A. Printing from other Programs.....	14
B. Printer Driver Settings.....	14
Section 3: Maintenance and Troubleshooting	16
A. Indicator Lights and Buttons.....	16
B. Cleaning the Print Head.....	17
C. Replacing the Print Head.....	18
D. Troubleshooting Print Quality.....	20
E. Repairing/Preventing Ribbon Breaks.....	22
F. Retrieving a Broken or Stuck Slide.....	23
G. Cartridge or Ribbon Recognition Problems.....	25
H. Technical Support.....	26
Section 4: Technical Specifications	27

Interactive Feature in this PDF Document

There are interactive features that will allow you to jump to different locations within the document. Each listing in the Table of Contents is interactive. Place the cursor on either the words or the page number. A small hand with a pointing finger icon appears. Click on the line with the icon and the document will jump to that page. If you want to return to the Table of Contents, move the icon to the top of the page and click on the arrow marked TOC.

Section 1: Getting Started

THANK YOU...

...for purchasing a Signature Slide Printer. The Signature Slide Printer can significantly increase the efficiency of your lab while helping to reduce the risk of misidentification of specimens. It prints directly onto slides, eliminating hand-writing or expensive, difficult to apply xylene-resistant labels. With impressive 300 dpi print resolution, you can print text, graphics and logos along with high-resolution linear and 2D bar codes on every slide you process.

To begin using your Signature, please read this manual carefully. This Operator's Manual is a guide to the Signature Slide Printer only. There are other accessories and software that work with the Signature Slide Printers. Those items are purchased separately and include their own user's manual.

NOTE ON TERMS AND CONVENTIONS

From this point forward, the following terms and conventions will apply:

The Signature Slide Printer will be referred to simply as the Printer.

A. CHOOSING A GOOD LOCATION

- Place the Printer in a location with adequate air circulation to prevent internal heat build-up. You will need at least 16" (41 cm) of overhead space to allow the top cover to open freely.
- Do not place the Printer near heat sources such as radiators or air ducts, or in a place subject to direct sunlight, excessive dust, mechanical vibration or shock.

B. UNPACKING AND INSPECTION

While unpacking your Printer, inspect the carton to ensure that no damage has occurred during shipping. Make sure that all supplied accessories are included with your unit.

The following items should be included:

- Signature Slide Printer
- Power cord
- Power converter
- USB cable
- 100 pack of slides
- Blue slide cartridge
- One standard color ribbon
- One Tuffcoat black ribbon
- Print head cleaning pen
- Installation disc and documentation

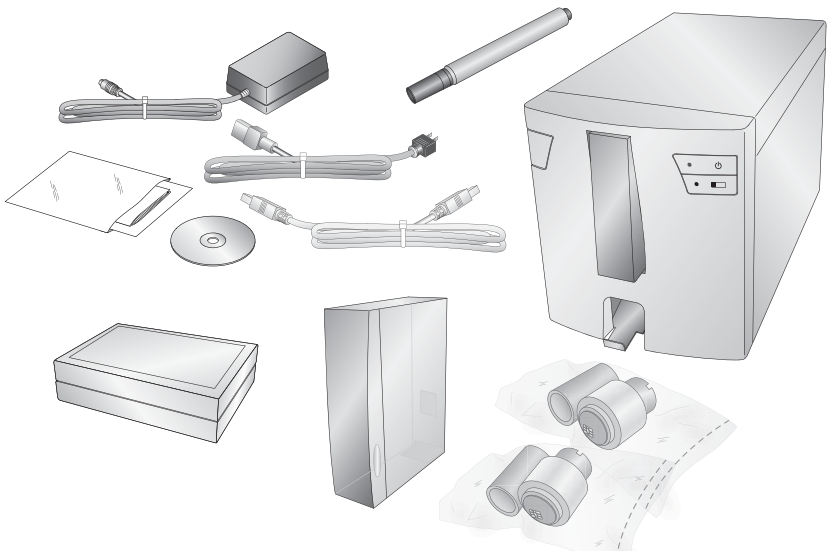

C. IDENTIFYING THE PARTS

The following illustrations show the various parts of the printer. These parts will be referred to throughout this manual so return here if you ever encounter a term that is unfamiliar to you.

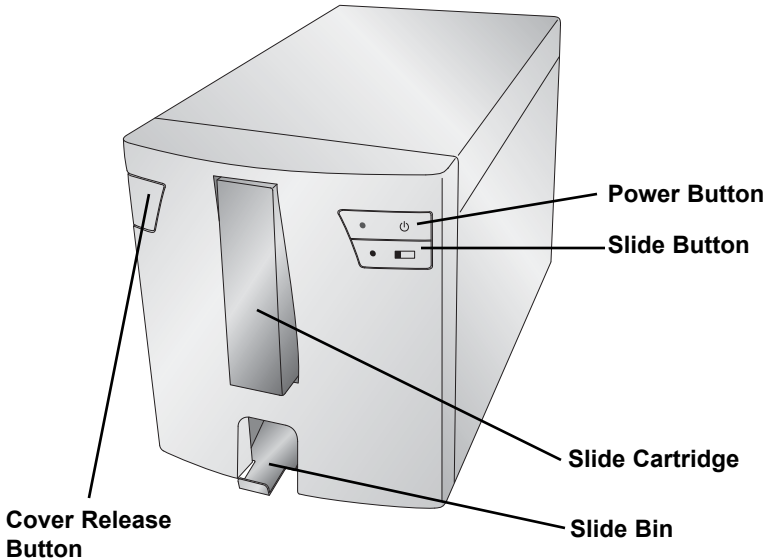

The **Cover Release Button** is a mechanical button that releases the spring-loaded mechanism on the cover.

The **Power Button** turns off the printer when the cover is closed. When the cover is open, press and hold the power button to reverse the slide rollers motors.

The **Slide Button** will advance any slide stuck in printer to the Slide Bin. When the cover is open, press and hold the slide button to advance the slide roller motors.

The **Slide Bin** will hold 15 Slides when it is fully ejected. Pull the Slide Bin forward to fully eject it. A sensor will trip if more than 15 standard 1mm slides are in the bin.

Rear View

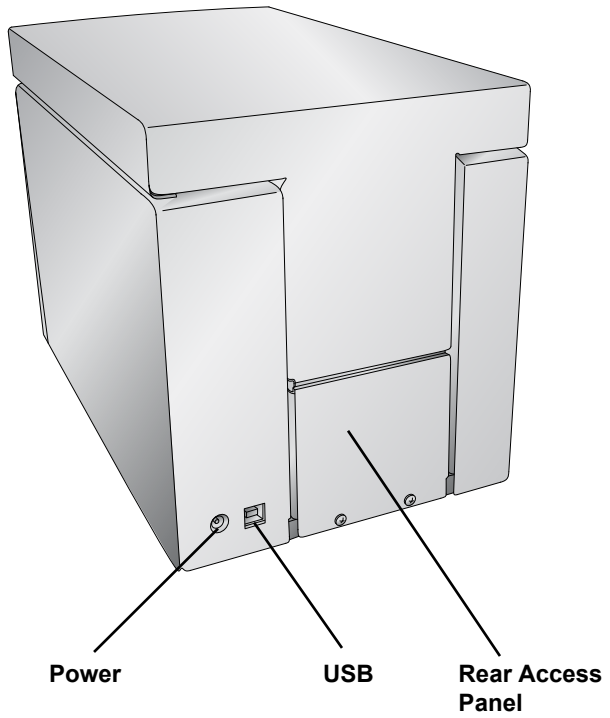

D. SLIDE SPECIFICATIONS

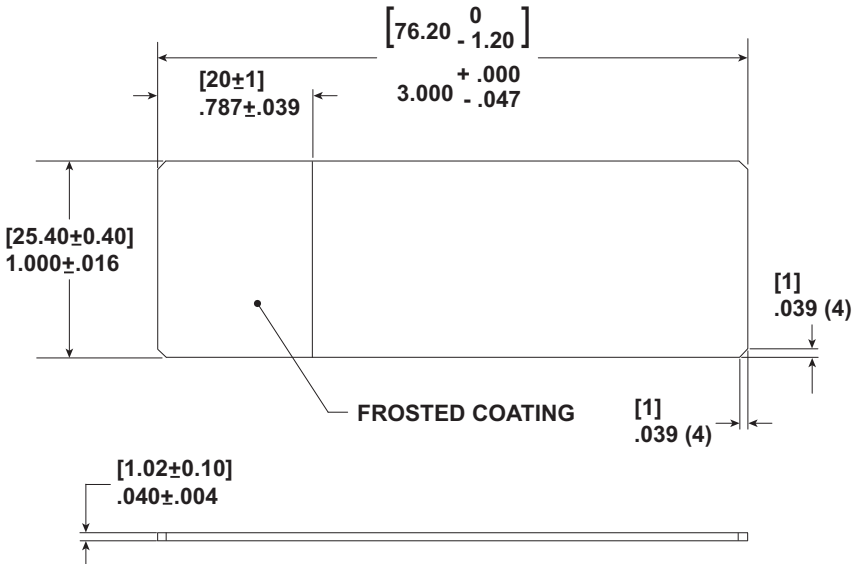

Slides should be 1.00" x 3.00" x .040" with clipped corners (1mm x 1mm). They should have ground edges and should be made from soda lime glass. Slides must have a coated white frosting. The frosted coating should cover 20mm of the length of the slide. The coating must be of uniform thickness across the entire width of the slide. The Signature Slide Printer uses thermal transfer print technology. This print technology requires stricter standards on the surface finish and cleanliness of the slide's frosted coating compared to slides that are used with ink jet technology printers. The coating must be smooth and free of any clumps or dust embedded in the coating or print defects will occur.

E. CONNECT POWER

Attach the power cord to the Power brick. Plug the power cord into a grounded outlet and the 5mm barrel connector to the back of the printer. The power converter is a universal 100v-240v input and a 12v output.

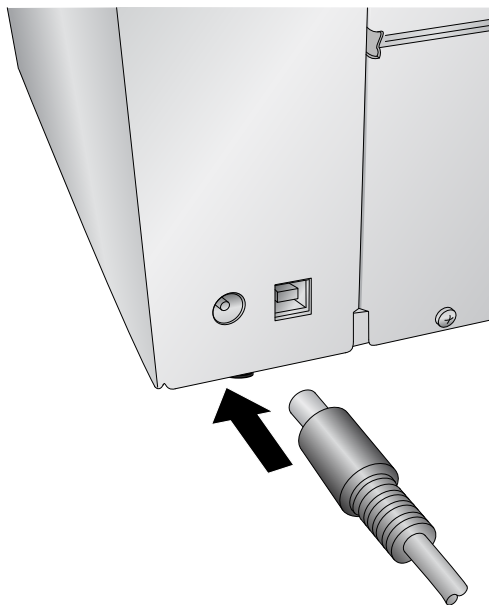

DO NOT CONNECT USB UNTIL THE PRINTER DRIVER HAS BEEN INSTALLED.

F. LOAD A RIBBON

The Signature Slide Printer uses either a Black ribbon (5000 prints) or a CMYK Color ribbons (1000 prints). You must use Primera ribbons to print with the Signature Slide Printer.

1. Remove a Color or Black Ribbon from its packaging. Detach the take up ribbon from the supply ribbon by gently pulling them apart.

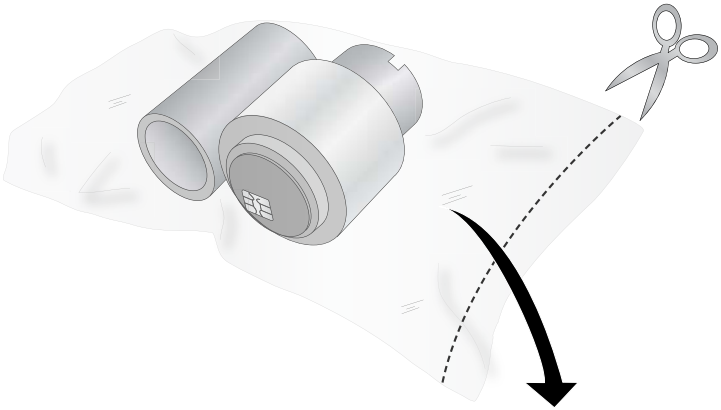

2. Open the top cover by pressing the release button on the left side of the printer.

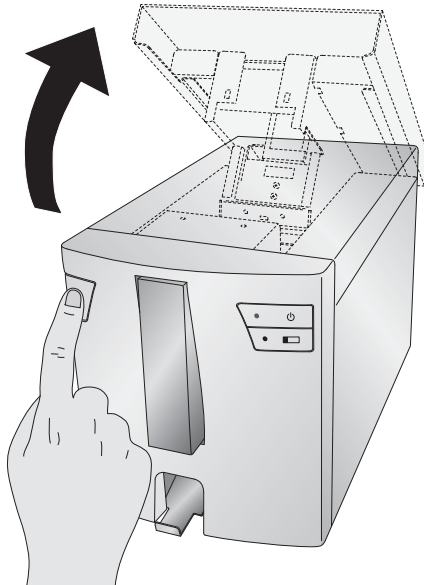

3. Remove the ribbon from its shrink wrapped packaging. Hold the take up (back) ribbon core with your left hand. Hold the supply (front) ribbon with your right hand. Install the take up ribbon by depressing the spring loaded hub inside the printer. Snap the take up ribbon core into place.

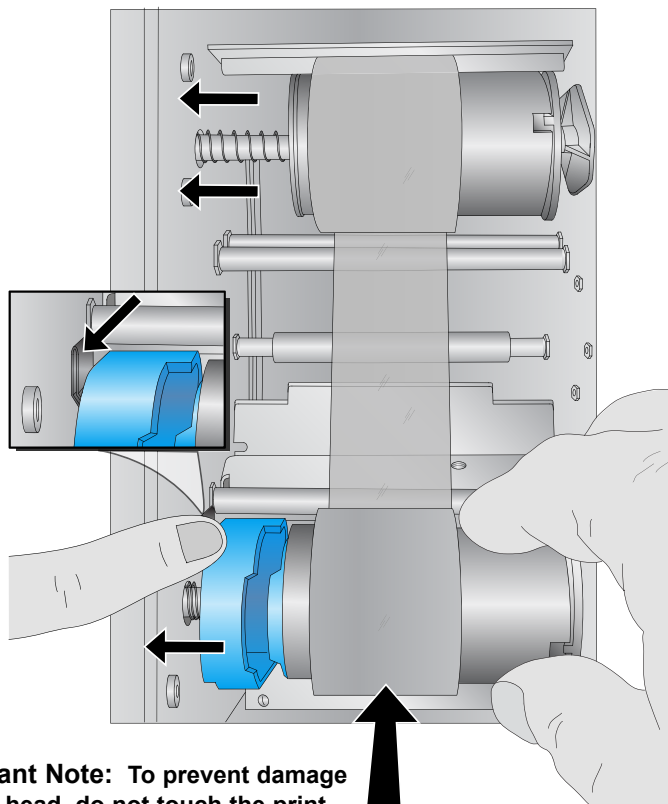

Important Note: To prevent damage to print head, do not touch the print head with a finger ring containing diamond or metal.

4. Push the blue spring loaded hub by depressing the tab with your left pointer finger. Insert the supply ribbon straight down. Match the blue shape on the ribbon to the corresponding depression on the hub. (You may need to rotate the blue shape on the ribbon.)

5. Rotate the hubs until the tabs on the right side hubs match the notches on the ribbon. Manually turn the take up core until the ribbon is taut.

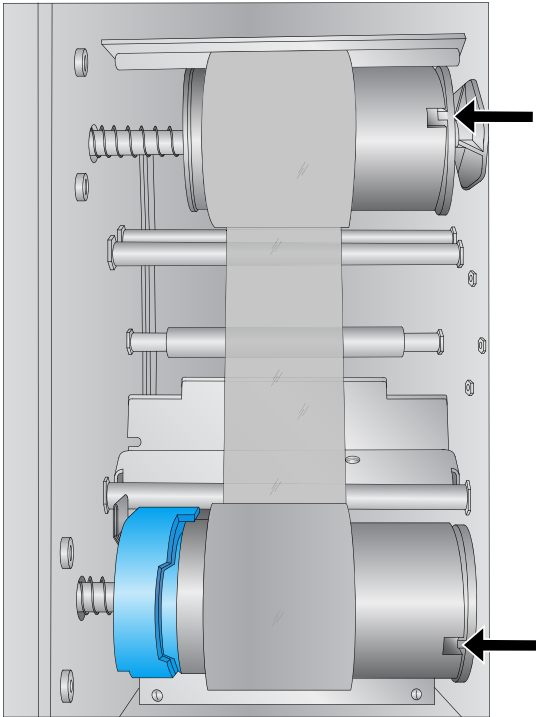

G. LOAD A SLIDE CARTRIDGE

1. Remove the empty blue slide cartridge by pulling up and out.

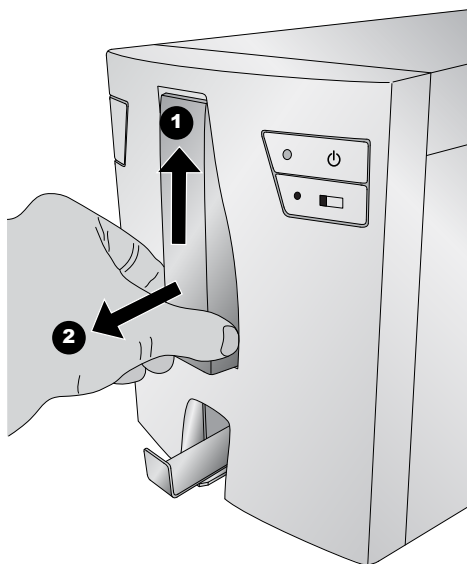

2. Open the blue side cartridge.

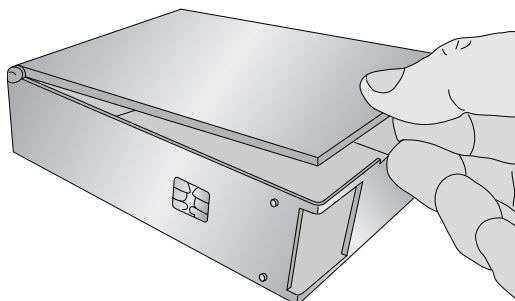

3. Locate the 100 pack slide box.

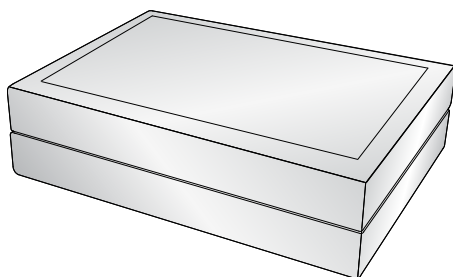

4. Place the slides next to the blue side cartridge so that the printable surface is on the TOP of the slide with the orientation shown below. **Note:** To achieve the proper orientation, it may be necessary to replace the box top, flip the box over and remove the other side of the box.

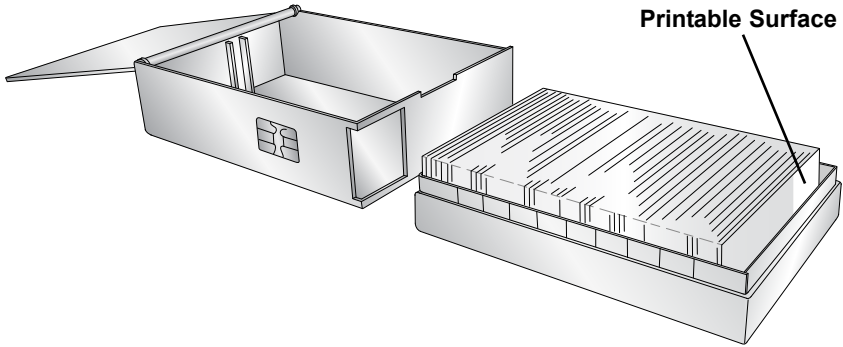

5. Carefully tip the slide box into the slide cartridge. The bottom slide in the box should rest on the edge of the slide cartridge. Note the location of the printable surface.

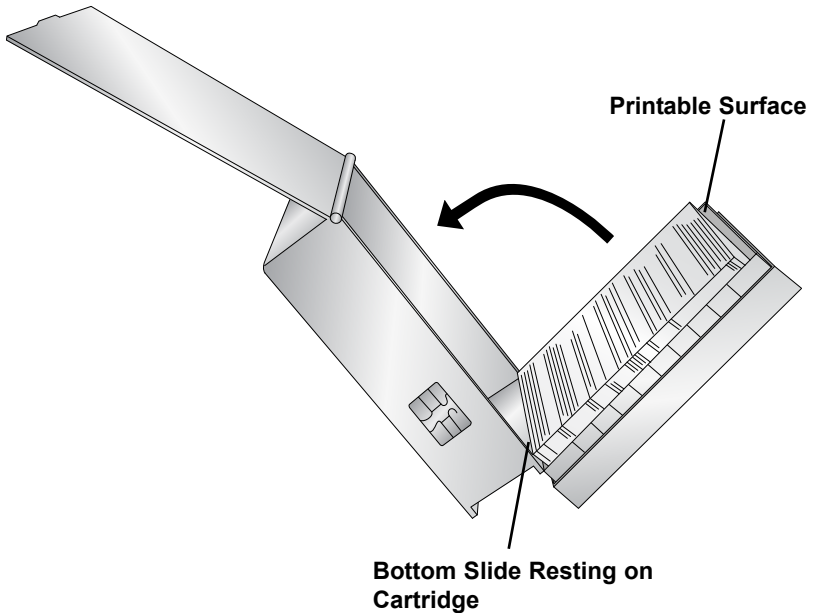

- Once the slides are in place, straighten any that did not properly fall in the cartridge and ensure the printable surface is facing up and near the front of the cartridge as it is placed in the printer.

Printable Surface

Important Note! To prevent feeding problems, a.) fan the slides with your latex glove protected finger and b.) never touch the slide surface without latex gloves!

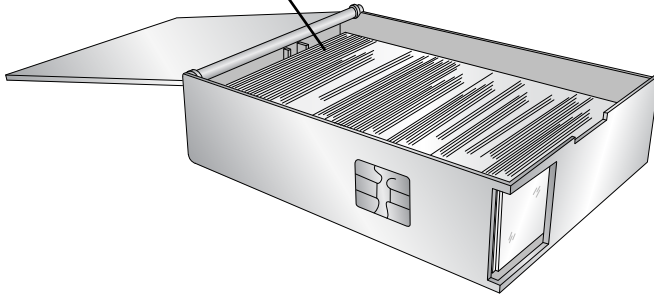

- Close the lid and insert the cartridge into the printer. Push near the bottom of the cartridge until you hear a click.

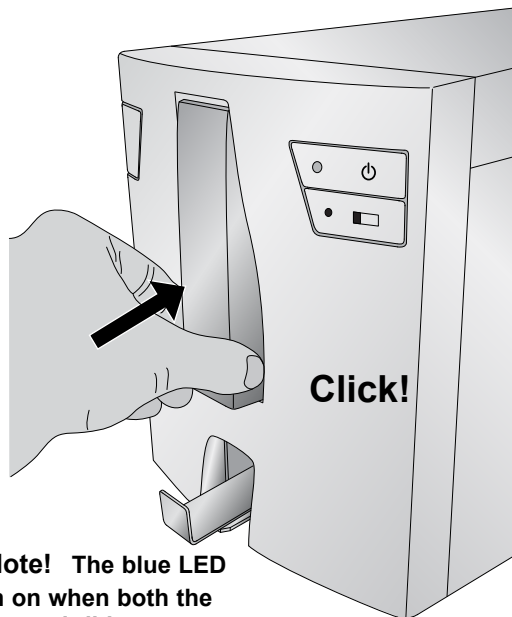

Important Note! The blue LED light will turn on when both the slide cartridge and ribbon are correctly installed.

H. INSTALL THE PRINTER DRIVER

If you have purchased the Primera Touch Screen you will not need to install the printer driver. It will be preinstalled on the Touch Screen. If you have your own computer that you will be connecting to Printer please follow these instructions.

1. Insert the installation disc.

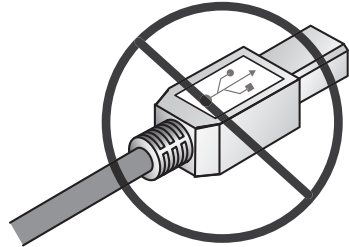
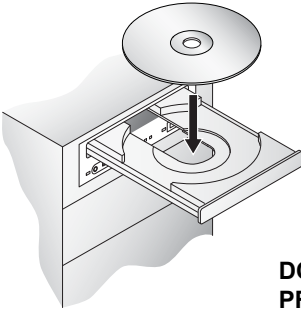

DO NOT PLUG IN THE USB CABLE UNTIL PROMPTED BY THE INSTALLER.

2. Follow the prompts in the installer to install the printer driver.
3. Finally plug in the USB cable to complete the installation.
4. When the printer driver has been installed successfully you will see a "Slide Printer" icon in your Devices and Printers.

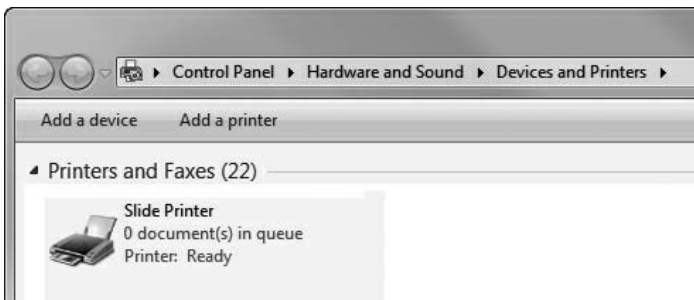
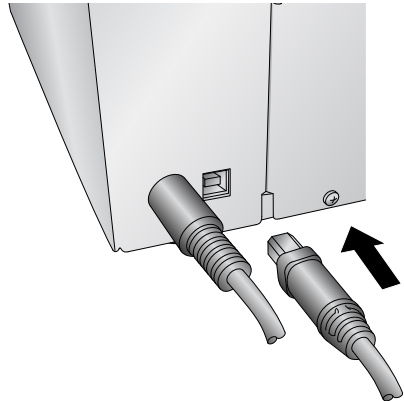

Section 2: Printing Slides

If you have purchased the Primera PTLAB software or the Primera Touch Screen Computer with the PTLAB software you can use it to print to the Signature Slide Printer. The PTLab software has its own manual. Please refer to it for detailed capabilities.

A. PRINTING FROM OTHER PROGRAMS

Printing to the Slide Printer from other software can be accomplished by using the standard Windows driver. The document requirements are listed below:

- Default Page = .87" (22mm) W x .67" (17mm) H
- Colors = Cyan, Magenta, Yellow, Red, Blue/Purple, Green, Black
- All colors must be 100% saturated

To print, simply go the applications print function. Choose the "Slide Printer" as the printer. Click OK to print.

B. PRINTER DRIVER SETTINGS

Click the Start button, choose Printers and Faxes (XP), Printers(Vista), Devices and Printers (Windows 7). Right-click on the Slide Printer Icon and select Printing Preferences from the drop-down menu.

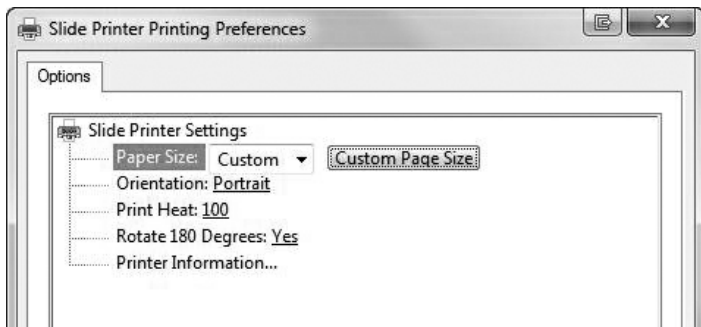

Paper Size: Default paper size is set to the maximum. Edit these settings if you are printing to slides with a smaller printable area.

Orientation: Change the orientation to Portrait or Landscape.

Print Heat: Increase or decrease the Print Heat from 1-255. Increase to print heat to improve print quality. 100 is the default value. Sustained use of a high print heat values will decrease the life of the print head and potentially break the ribbon. Different manufacturers of slides may require more or less heat. The minimum heat settings possible that result in a good print should be used.

Rotate 180 Degrees: Flips the image up-side down . Default setting is Yes.

Printer Information... Click here to display, printer driver versions, firmware versions, total prints, current status, remaining slides, remaining prints and offset values.

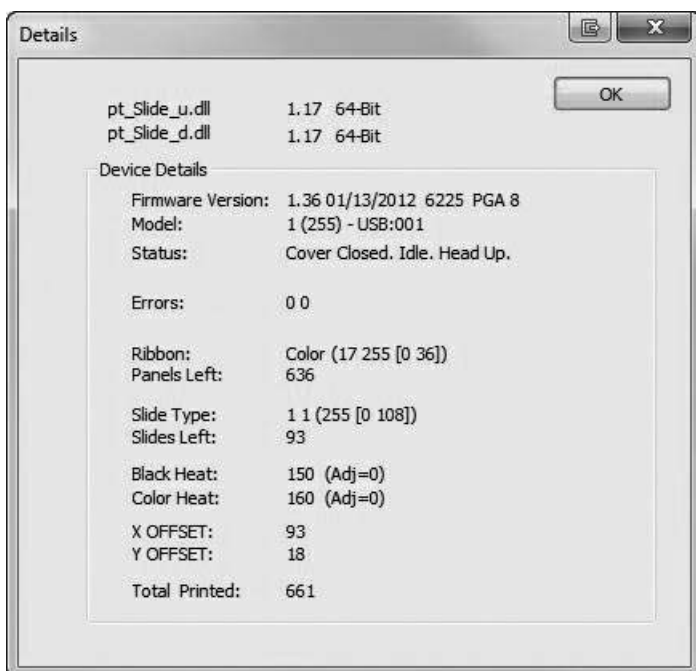

Section 3: Maintenance and Troubleshooting

A. INDICATOR LIGHTS AND ERROR CODES

Power light on Steady - Slide Cartridge light ON	Ready to receive Print.
Power light on Steady - Slide Cartridge light OFF	No ribbon installed and/ or No Slide Cartridge Installed.
Flashing Slide Cartridge light and slide button light	An error is present. Refer to error code or error message displayed in the printer information dialog in the printer driver preferences area. See the error code list below. (PTLab will display these errors in the software)

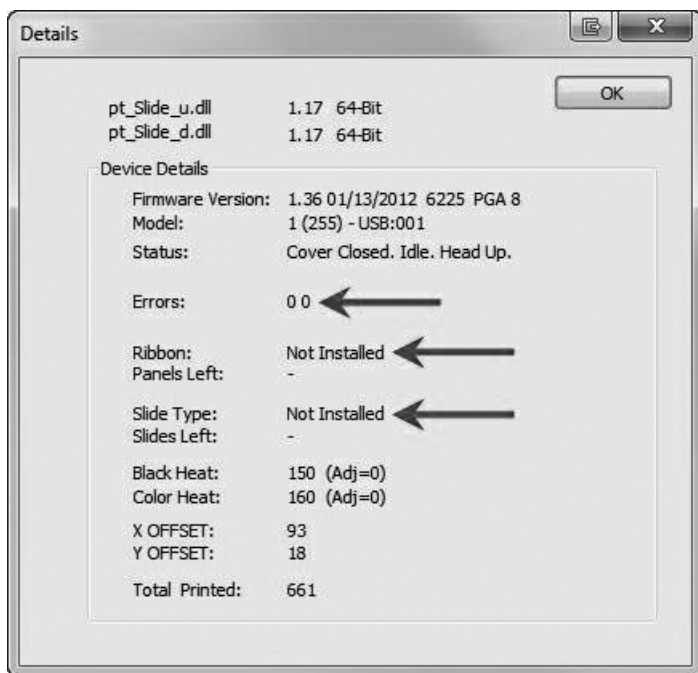

Slide Cartridge Invalid	80 0
Ribbon PWM	40 0
Head Load	20 0
Input Empty	10 0
Input Jam	08 0
Ribbon Advance Error	04 0
Ribbon Invalid	02 0
Lifter Not Functioning	01 0
Ribbon Out	00 01
Ribbon Break	00 02
Output Full	00 08
Slide Connection Error	00 10
Ribbon Connection Error	00 20
Ribbon Jam Error	00 40

B. CLEANING THE PRINT HEAD

A print head cleaning pen is included with the printer. Clean the print head after every ribbon change or if you notice quality problems such as vertical line through the entire print.

1. Unplug Power.
2. Open the printer cover.

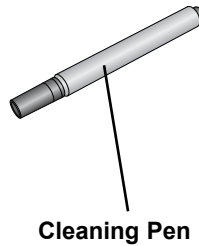
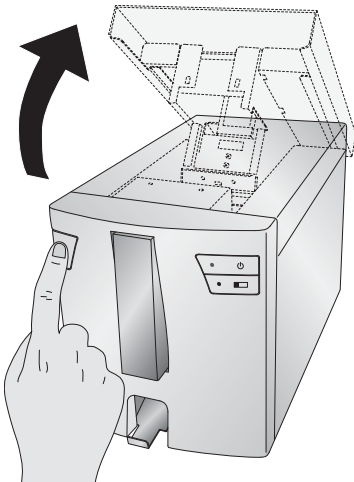

3. Locate the Print head mounted to the underside of the cover.

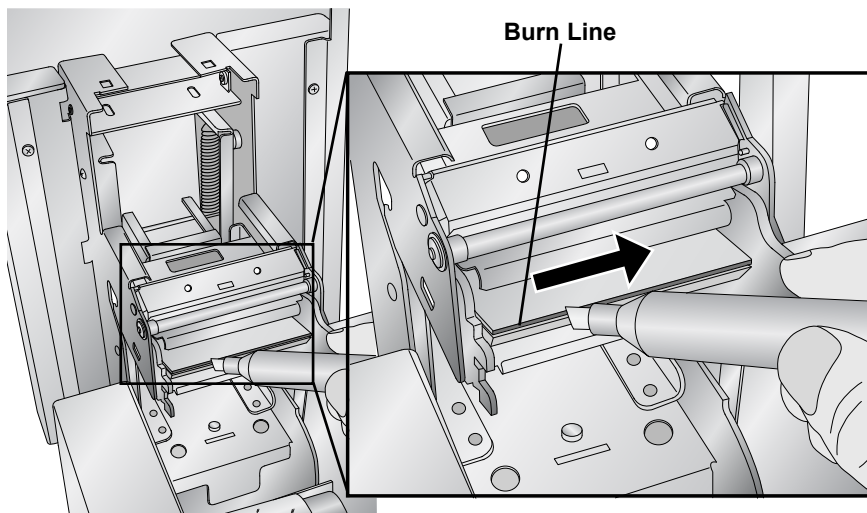

4. Clean the print head using the print head pen. Swipe the tip across the burn line 1 or 2 times. If you notice the tip getting dirty, clean it by wiping it across a clean paper surface.

C. REPLACING THE PRINT HEAD

If cleaning the print head (Section 3B) does not resolve a quality problem such as a vertical line through the entire print, it may be time to replace the print head. Print heads are designed to last tens of thousands of prints. However, it is possible a premature failure could occur if high heat settings were continuously used, it is used in a particularly hot environment or if slides not recommended for the printer are used. **Print Head Part Number : 78250**

1. Unplug Power.
2. Open the printer cover.
3. Locate the Print head mounted to the underside of the cover.



4. Push back , then down and then flip it 180 degrees to reveal the cable connector. Watch the pin on the side of the print head mechanism to guide the print head out of the metal housing.

Important Note: To prevent damage to print head, do not touch the print head with a finger ring containing diamond or metal.

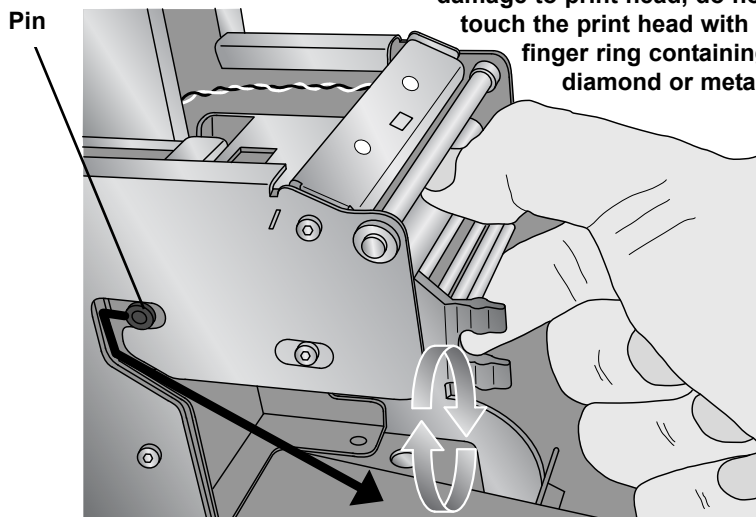

5. Disconnect the cable from the connector. Pull on the cables to remove the connector.

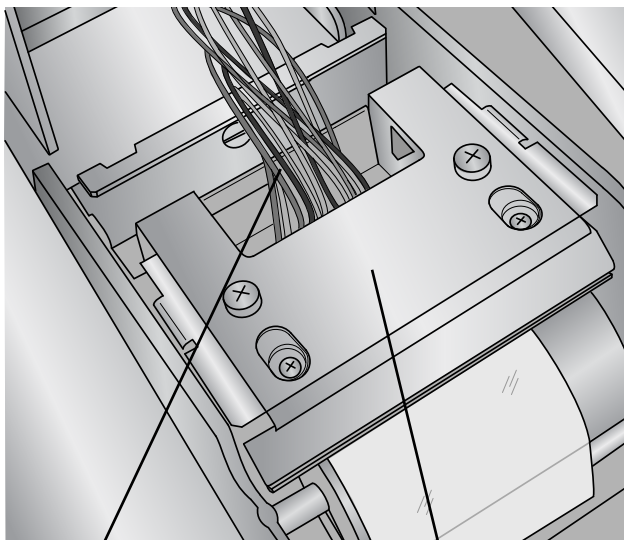

Disconnect this Cable

Print Head Flipped 180 Degrees

6. Connect the new print head.
7. Rotate the printhead 180 degrees and push it back into the metal housing.
8. **IMPORTANT!** Find the Resistance value printed on the the printhead.

Example: R= 3180

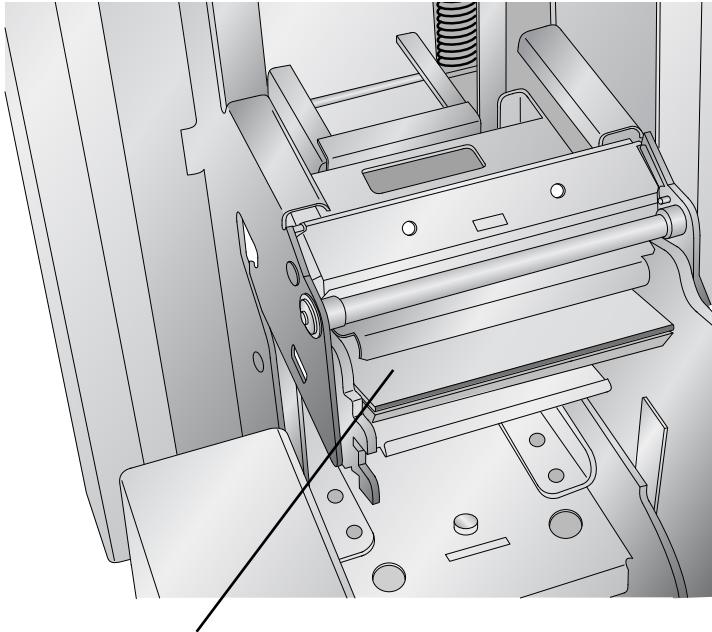





Resistance Value Printed Here



Before printing, enter this value in the advanced settings area of the PTLab software.

Click the settings icon in the upper right corner of software. To enable the advanced area of settings hold SHIFT + A. Now click on Advanced Settings. Enter the the Head Resistance. Click Set.

D. TROUBLESHOOTING PRINT QUALITY

Print Quality problems are usually caused by debris or flaws on the printable surface of the slide. Use the chart below to diagnose quality problems.

 <p>PatientID 2012-02-02 01 Tissue ID 1 of X</p>	<p>Vertical Line. A line vertically through the entire print is caused by dust or debris on the print head burn line or blown pixel on the print head. See Section 3B for cleaning instructions and 3C for print head replacement instructions.</p>
 <p>PatientID 2012-02-02 01 Tissue ID 1 of X</p>	<p>Horizontal Line. A horizontal line through the print is caused by a small bump on the slide. This causes the entire print head to lift at this point so the effect of the bump is extended to the left and right of the bump. Low quality or defective slides may be the cause.</p>
 <p>PatientID 2012-02-02 01 Tissue ID 1 of X</p>	<p>Group of Spots. This may be caused by dust particles on the slide. Keep the slide clean. Store them in the blue slide cartridge at all times. Avoid handling the slides. Do not remove them from their shrink wrapping until you will be inserting the slides into the blue cartridge.</p>
 <p>PatientID 2012-02-02 01 Tissue ID 1 of X</p>	<p>Light Printing. Light printing is caused by insufficient heat or slides that are not thermal printable (inkjet). You may be able to improve quality by increasing the heat setting in the Printer Preferences or the PTLab software. Different manufacturers of slides may require more or less heat. The minimum heat settings possible that result in a good print should be used. (Section 2B)</p>
 <p>PatientID 2012-02-02 01 Tissue ID 1 of X</p>	<p>Random Missing Area (Print Surface Intact). This is caused by a rough printable surface. Low quality slides, defective slides or slides that are not thermal printable (inkjet) may be the cause.</p>

 <p>The image shows a PatientID label with the following text: "PatientID", "2012-02-02", "01 Tissue", "ID", and "1 of X". A QR code is on the right. A grey rectangular area at the top of the label is missing, and a white arrow points to this area.</p>	<p>Random Missing Area (Printable Surface Missing). If the printable surface is missing or scratched off, the printer cannot print in these areas. Low quality slides, defective slides or mishandling of slides may be the cause of this problem.</p>
 <p>The image shows a PatientID label with the following text: "PatientID", "2012-02-02", "01 Tissue", "ID", and "1 of X". A QR code is on the right. The top edge of the label is rounded.</p>	<p>Rounding at the leading edge. Rounding at the leading edge of any new color on a slide is typically caused by low quality slides or slides that are not thermal printable (inkjet).. If changing slides is not an option consider modifying your template to include a print quality line at the bottom of the printable area.</p>

E. REPAIRING/PREVENTING RIBBON BREAKS

Ribbon breaks can occur if the head setting is too high. To repair a ribbon break follow this procedure:

1. Open the cover.
2. Locate the supply roll ribbon. Place it on the top of the print as shown below. Attach a piece of tape.

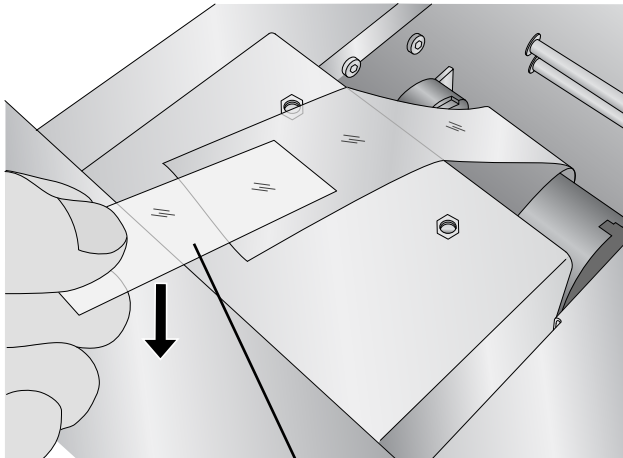

Tape Sticky Side Down

3. Feed the supply side of the ribbon under the take up roll.
Tape the supply ribbon to the take-up roll.

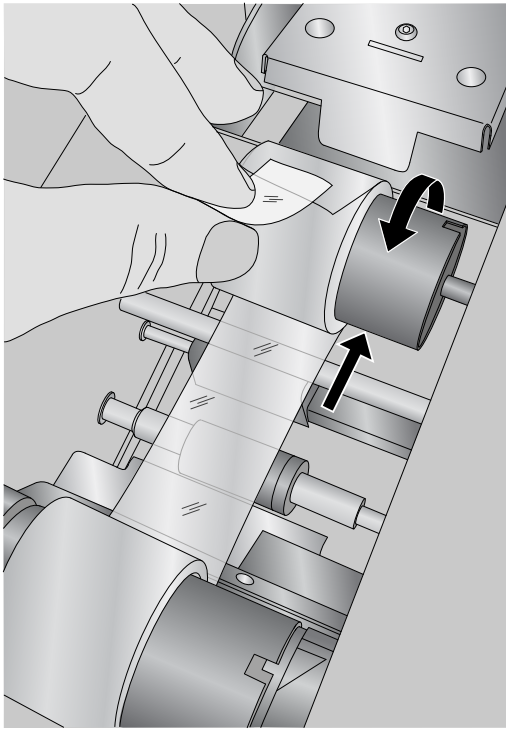

4. Manually turn the take-up roll several complete rotations to prevent the tape from coming loose.
5. Close the Cover.

F. RETRIEVING A BROKEN OR STUCK SLIDE

If a slide is broken or stuck in the system there are two access panels that can be used to retrieve the slide. If a slide is found inside the printer, use the Power and Slide buttons to move the internal slide rollers forward and back to advance the slide to a point where it can be removed. Follow this procedure:

1. Open the top cover.
2. Remove the Ribbon.

3. Remove the slide cartridge.

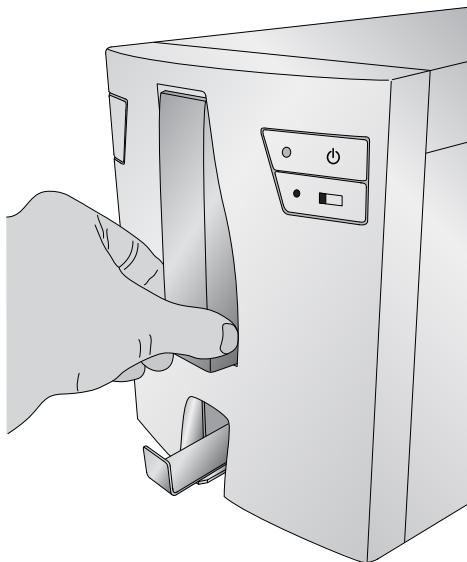

4. In the slide cartridge compartment check near the bottom roller for a slide.
5. Check under the ribbon. Use the Power and Slide buttons to move the slide to a position where you can remove it.

Tip! *Once the slide is on the rubber belts near the back, you can close the cover and press the slide button to advance the side down the slide chute.*

6. If the slide is near the back and you are unable to retrieve it using the buttons you can remove the back cover panel.

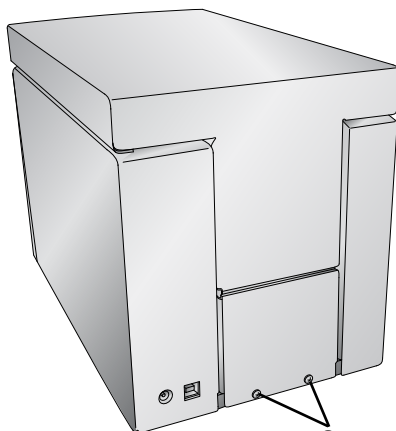

Screws for Access Panel

7. Finally if the slide is broken you can remove it using the bottom catch bin. Pick up the slide printer and rotate it in multiple directions until all of the pieces are in the bin. Now pull out the bin and empty it into the trash.

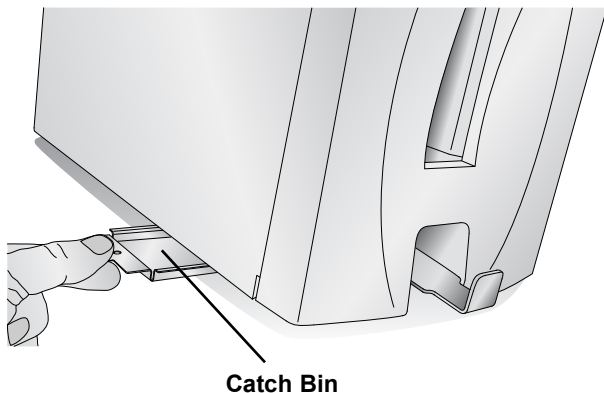

G. CARTRIDGE OR RIBBON RECOGNITION PROBLEMS

If your cartridge or ribbon is installed but the blue LED light behind the cartridge does not turn on or the software says no cartridge or ribbon is installed, you may need to clean the copper chip on the ribbon or cartridge.

Use Isopropyl Alcohol and a soft cloth to wipe the copper chip on the ribbon or slide cartridge.

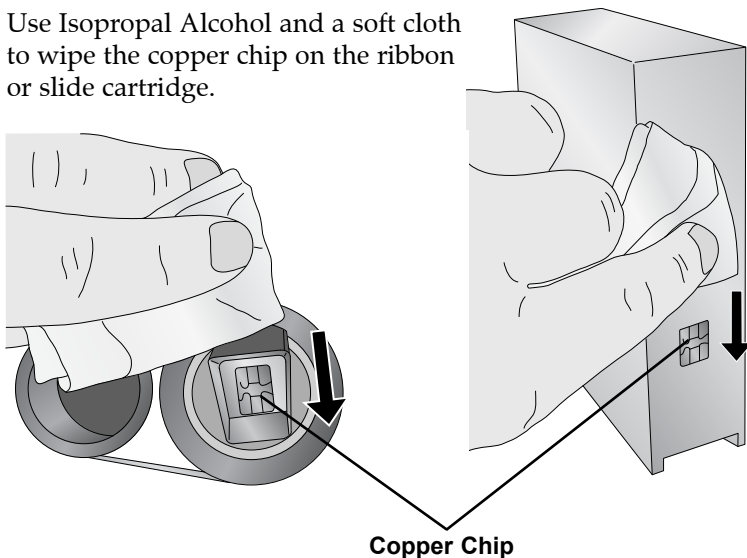

H. TECHNICAL SUPPORT

If you have difficulties in operating your Printer, the procedures in this manual and the software User's Guide should, in most cases, solve the problem. If you still have difficulty, contact the technical support number using one of the methods listed below.

Source	Location
Primera Knowledge Base	www.primera.com/kb
Email Support	www.primera.com/contact_tech_support.cfm
Phone Support	763-475-6669 (Mon - Fri 8 a.m. - 6 p.m CST)

Section 4. Technical Specifications

Printing technology:	Thermal transfer
Print speed:	Up to 7 slides/minute (monochrome) Up to 5 slides/minute (solid colors) Up to 3 slides/minute (process colors)
Print resolution:	300 dpi
Ink type:	Resin thermal transfer
Ribbon types:	CMYK: 1000 prints Black: 5000 prints
Printable colors:	8 solid colors
Slide types:	3" x 1" standard or positive charged, white frosted end, clipped corners
Slide capacity:	100 slides/cassette
External cassette capacity:	100 slides
Output tray capacity:	15 slides
Construction:	Steel frame with powder-coated steel and plastic covers
Cabinet color:	Medical white
Data interface:	USB 2.0
Printer drivers:	Windows™ XP/Vista/7
Height:	8.6" (218.4mm)
Width:	7.08" (179.8mm)
Depth:	12.58" (319.5mm)
Weight:	16.8 lbs. (7.62 kg)
Power requirements:	100-240VAC, 50/60 Hz, 60 watts
Warranty:	One year parts and labor

