

Leica RM 2145

Rotary Microtome

Instruction Manual

Leica RM 2145 V3.1 English – 02/2001

Always keep this manual near the instrument!
Read carefully prior to operating the instrument!

Leica

MICROSYSTEMS

Serial No.

Year of manufacture

Manufactured in: Federal Republic of Germany

The information, numerical data, notes and value judgments contained in this manual represent the current state of scientific knowledge and state-of-the-art technology as we understand it following thorough investigation in this field. We are under no obligation to update the present manual periodically and on an ongoing basis according to the latest technical developments, nor to provide our customers with additional copies, updates etc. of this manual.

For erroneous statements, drawings, technical illustrations etc. contained in this manual we exclude liability as far as permissible according to the national legal system applicable in each individual case. In particular, no liability whatsoever is accepted for any financial loss or consequential damage caused by or related to compliance with statements or other information in this manual.

Statements, drawings, illustrations and other information as regards contents or technical details of the present manual are not to be considered as warranted characteristics of our products. These are determined only by the contract provisions agreed between ourselves and our customers.

Leica reserves the right to change technical specifications as well as manufacturing processes without prior notice. Only in this way is it possible to continuously improve the technology and manufacturing techniques used in our products.

This document is protected under copyright laws. Any copyrights of this document are retained by Leica Microsystems Nussloch GmbH.

Any reproduction of text and illustrations (or of any parts thereof) by means of print, photocopy, microfiche, web cam or other methods – including any electronic systems and media – requires express prior permission in writing by Leica Microsystems Nussloch GmbH.

For the instrument serial number and year of manufacture, please refer to the name plate at the back of the instrument.



Leica Microsystems Nussloch GmbH

Heidelberger Str. 17-19
D-69226 Nussloch
Germany

Telephone: 0 62 24 / 143-0
Telefax: 0 62 24 / 143-200
eMail: histo-info@leica-microsystems.com
Homepage: <http://www.histo-solutions.com>

© Leica Microsystems Nussloch GmbH

2. Table of contents

1.	Important information	3
2.	Table of contents	4
3.	Safety instructions for handling the instrument	5
4.	Technical data	9
5.	General description	10
5.1	Product description	10
5.2	Standard delivery	10
5.3	Leica RM 2145 - overall view of the instrument.....	11
6.	Unpacking and installation	12
6.1	Unpacking	12
6.2	Assembling the handwheel	14
6.3	Site requirements	14
7.	Setting up the instrument	15
7.1	Connecting to mains	15
7.2	Installing the arm rests	18
7.3	Switching on the instrument.....	18
7.4	Control panel functions	19
8.	Daily routine operation	29
8.1	Inserting the specimen clamp	29
8.2	Assembling the specimen clamp directly to the fixture for specimen clamps.....	29
8.3	Clamping the specimen	30
8.4	Installing the knife holder base	30
8.5	Installing the knife holder	30
8.6	Inserting the knife or disposable blade	31
8.7	Adjusting the clearance angle	31
8.8	Orienting the specimen (only with orienting specimen clamp fixture)	32
8.9	Trimming	33
8.10	Sectioning	33
8.11	Changing specimens and/or pausing	34
8.12	Finishing daily routine	34
9.	Trouble shooting	35
9.1	Instrument malfunctions	35
9.2	Potential sources of errors - elimination	36
9.3	Malfunctions - sources and elimination	37
10.	Cleaning	38
11.	Maintenance	39
11.1	General maintenance instructions	39
11.2	Adjusting the spring lever system	40
11.3	Replacing the fuses	41
12.	Optional accessories	42
12.1	Specimen clamps and holders	42
12.3	Knife holders	48
12.4	Section waste tray	53
12.5	Combined carrier with magnifier and illumination	54
12.6	Microscope carrier	57
12.7	Hand rest.....	59
12.8	Exchanging the fixture for specimen clamps	62
13.	Appendix	63
13.1	Ordering information	63
	Product changes	65
	Warranty	65
	Disposal.....	65
	Technical service information	65

3. Safety instructions for handling the instrument

3.1 Safety devices



The safety devices on the instrument must neither be removed nor modified in any way!

The instrument is equipped with the following safety devices: quick locking system for the handwheel and knife guard on the knife holder.

3.1.1 Activating the quick locking system of the handwheel



Before manipulating knife or specimen or changing the specimen and during breaks: always lock the handwheel and cover the knife edge with the knife guard!

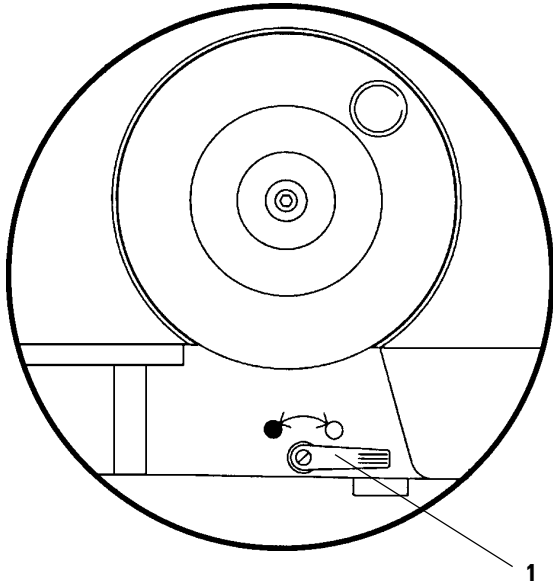

Fig. 5.1

The handwheel can be locked in any position with the locking lever (1) on the right side of the microtome base plate. The two locking positions of the lever (● = locked; ○ = released) are marked on the microtome base plate (Fig. 5.1)

Performance check

- To activate, pull the locking lever (1) to the front (●).

The handwheel is mechanically blocked and cannot be turned.

- To deactivate, push the locking lever (1) to the rear (○).

The handwheel can then be rotated again.

3. Safety instructions for handling the instrument

3.1.2 Knife guard on the knife holder



Before manipulating knife or specimen / before changing specimens and during breaks: always lock the handwheel and cover the knife edge with the knife guard!

All knife holders are equipped with a permanent, movable knife guard (1) which allows to cover the entire cutting edge with the knife clamped in any position.

Knife holders N

The knife guard of knife holder N (Fig. 6.1) has two small grips (2) for conveniently moving the knife guard rails.

To cover the knife edge, push both halves of the knife guard to the center.

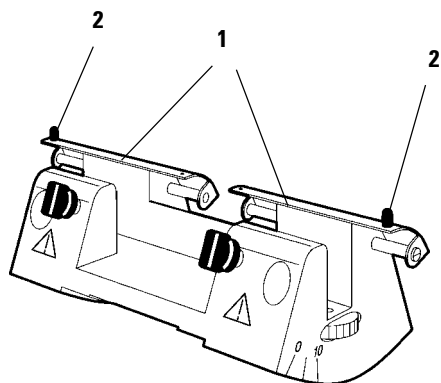

Fig. 6.1

Knife-holder E

Knife holder E (Fig. 6.2) is equipped with a tilting shackle (1) which functions as a knife guard.

To cover the knife edge, tilt the shackle (1) upwards.

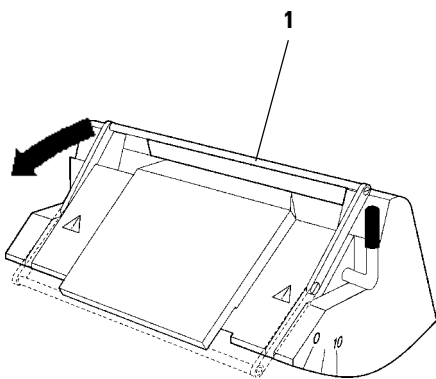

Fig. 6.2

Transport and installation



- Please pay careful attention to chapter 4 - 'Technical data'!
- The instrument may only be transported upright!
- **Caution:** The voltage selector is preset in the factory.
Before connecting the instrument to the mains power, please check whether the factory setting is identical with the local mains power in your lab!
The mains cable inlet is sealed with an adhesive tape that indicates the factory setting the instrument comes with.
- Severe damage may be caused to the instrument when operating it at an incorrect voltage setting.
- Do not change the voltage selector setting, with the instrument being connected to the mains.
- The instrument may only be connected to a grounded mains power outlet socket. To connect the instrument only use one of the mains cables that are supplied together with the instrument!
- In case of exposure to extreme temperature changes and high air humidity condensation may form inside the instrument. If that type of exposure has taken place, make sure to wait at least 2 hours before switching on the instrument to allow it to adapt to the local ambient temperature. Failure to allow for the required waiting time may cause severe damage to the instrument!
- Do not operate the instrument in rooms with explosion hazard!
- The safety devices on the instrument must neither be removed nor modified in any way!

Operating the instrument



- Be extremely careful when handling microtome knives and/or disposable blades! The cutting edges are extremely sharp and can cause severe injury!
- Never leave knives or knife holders with a knife / disposable blade inserted someplace unprotected! Always store knives in their knife case when not in use!
- Never place a knife anywhere with the cutting edge facing upwards!
- Never try to catch a falling knife!
- Always clamp the specimen before clamping the knife!
- Before manipulating knife or specimen / before changing specimens and during breaks: always lock the handwheel and cover the knife edge with the knife guard!
- Never attempt to orient the specimen while the instrument is in the retraction phase (i.e. while the yellow RETRACT indication is illuminated)!
Prior to the next section, the specimen will advance by the retraction value plus the selected section thickness! There is danger that specimen and knife will be damaged.
- Always wear safety goggles when sectioning brittle specimens! - Risk of splintering!
- Make sure that no liquids get into the interior of the instrument during work!

3. Safety instructions for handling the instrument

Cleaning



- Before cleaning, lock the handwheel, switch the instrument off and pull the mains plug!
- Only use mild household cleaners / soap for cleaning. The varnish paint coat of the instrument is not resistant to acetone or xylene!
- Make sure that no liquids get into the interior of the instrument while cleaning!
- After cleaning wait for the instrument to be completely dry before switching it back on!

Maintenance



- Only authorized Leica service engineers may open the instrument for maintenance and repair work!
- Before exchanging the fuses, switch the instrument off and pull the mains plug!
- When exchanging fuses, only use replacement fuses with the same specification as the original ones. - Refer to chapter 4 'Technical data' for the correct specifications.

Optional accessories

Combined carrier with magnifier and illumination



- Do not operate the magnifier / illumination carrier at a mains power other than the one specified on the name plate at the rear of the carrier.
- Do not expose the magnifier glass to direct sunlight! Direct sunlight may cause a burning glass effect. - Fire hazard!
- Before exchanging the lamp, switch it off with the mains switch and pull the mains plug of the carrier!
- Only use replacement lamps of the same specification as the original lamp.
- Before exchanging the carrier fuses, switch off the lamp with the mains switch and pull the mains plug of the carrier!
- Only use replacement fuses with the same specification as the original ones, inserted at works!

Type	RM 2145
Admissions	UL, cUL
Nominal supply voltages	100 / 120 / 230 / 240 V AC \pm 10%
Nominal frequency	50/60 Hz
Maximum power draw	70 VA
Protective class ^①	I
Mains fuses	2 x T 1,0 A UL-listed
Pollution degree	2
Overvoltage installation category	II
Maximum heat emission ^①	70 J/s
Working temperature range	+10 °C to +35 °C
Relative humidity	80%, non-condensing
^① according to IEC-1010, UL 3101, EN 61010	
Microtome	
Type	RM 2145 rotary microtome
Sectioning thickness setting	0.25 - 60 μ m 0.25 μ m, 0.5 μ m, 1 μ m, 1.5 μ m; 2 - 20 μ m in 1 μ m increments 20 - 60 μ m in 5 μ m increments
Total horizontal specimen feed	27 mm \pm 1 mm via step motor
Vertical specimen stroke	70 mm
maximum sectioning area, w/o retraction	65 mm, without specimen orientation
maximum sectioning area, with retraction	60 mm
Specimen retraction	0 - 100 μ m, in 5 μ m increments can be switched off
Motorized coarse feed	300 μ m/s and 900 μ m/s
Repositioning of knife holder base	
north / south	\pm 25 mm
lateral	\pm 20 mm
Maximum specimen size (W x H x D)	50 x 60 x 40 mm
Specimen orientation	
horizontal	8°
vertical	8°
rotation	\pm 90°
Dimensions and weight	
Main instrument	
Width (including handwheel)	370 mm
Width (w/o handwheel)	300 mm
Depth	550 mm
Height (overall)	285 mm
Working height (level of knife edge)	100 mm
Weight (w/o accessories)	38 kg
Control panel	
Width	140 mm
Depth	240 mm
Height	95 mm
Height (in inclined position)	125 mm
Weight (net)	2.4 kg

5. General description

5.1 Product description

The Leica RM 2145 is a semi-motorized rotary microtome.

The specimen feed system with zero-backlash and maintenance-free cross roller guides and the step motor operated coarse feed system are located in a dustproof plastic housing. Sectioning is performed by manually rotating the extremely smooth-running handwheel. The handwheel is lockable in any position via a mechanical quick locking system.

All settings, LED indications and control functions are centralized in a separate control panel. Control buttons and indications are logically arranged in functional groups.

The specimen retraction can be set in different thicknesses and can also be entirely switched off. The retraction phase is visually indicated.

The motorized coarse feed operates at two speeds. In the trimming mode, the coarse feed buttons have a TRIM-STEP function.

The instrument offers two different manual sectioning modes: conventional sectioning by complete handwheel rotations and sectioning in the 'Rocking Mode', where the handwheel only needs to be moved back and forth over a small distance in each direction.

The instrument also has a number of special functions, such as the programmable horizontal specimen stop-function, and the sectioning and trimming program.



The plastic grips of all clamping levers can be repositioned according to individual user preference.

To reposition, pull out the grip of the lever, hold it firmly in the pulled-out position and turn it to the desired position. When releasing it, it will lock automatically in the new position.

5.2 Standard delivery

The Leica RM 2145 basic instrument is delivered without accessories in the following configuration:

- 1 fixture for specimen clamps, orienting,
- 1 arm rest - right,
1 arm rest - left,
- 1 maintenance kit, consisting of:
 - 1 Allen key, size 5,
 - 1 Allen key, size 4,
 - 1 Allen key, size 3,
 - 2 screwdrivers,
 - 1 bottle of microtome oil, no. 405, 50 ml,
 - 1 dust cover,
- 1 set of replacement fuses,
- 1 set of mains cables,
- 1 separate control panel,
- 1 instruction manual.

You will find these, and any further accessories you may have ordered, packed in a cardboard box located on top of the instrument.

Compare the actually delivered components with the parts list and your order.

If there are any discrepancies, please contact your Leica sales office immediately.

5. General description

5.3 Leica RM 2145 - overall view of the instrument

Cover cap,
access to the internal fitting device for mounting the
combined carrier * for magnifier / illuminations or the
microscope carrier *

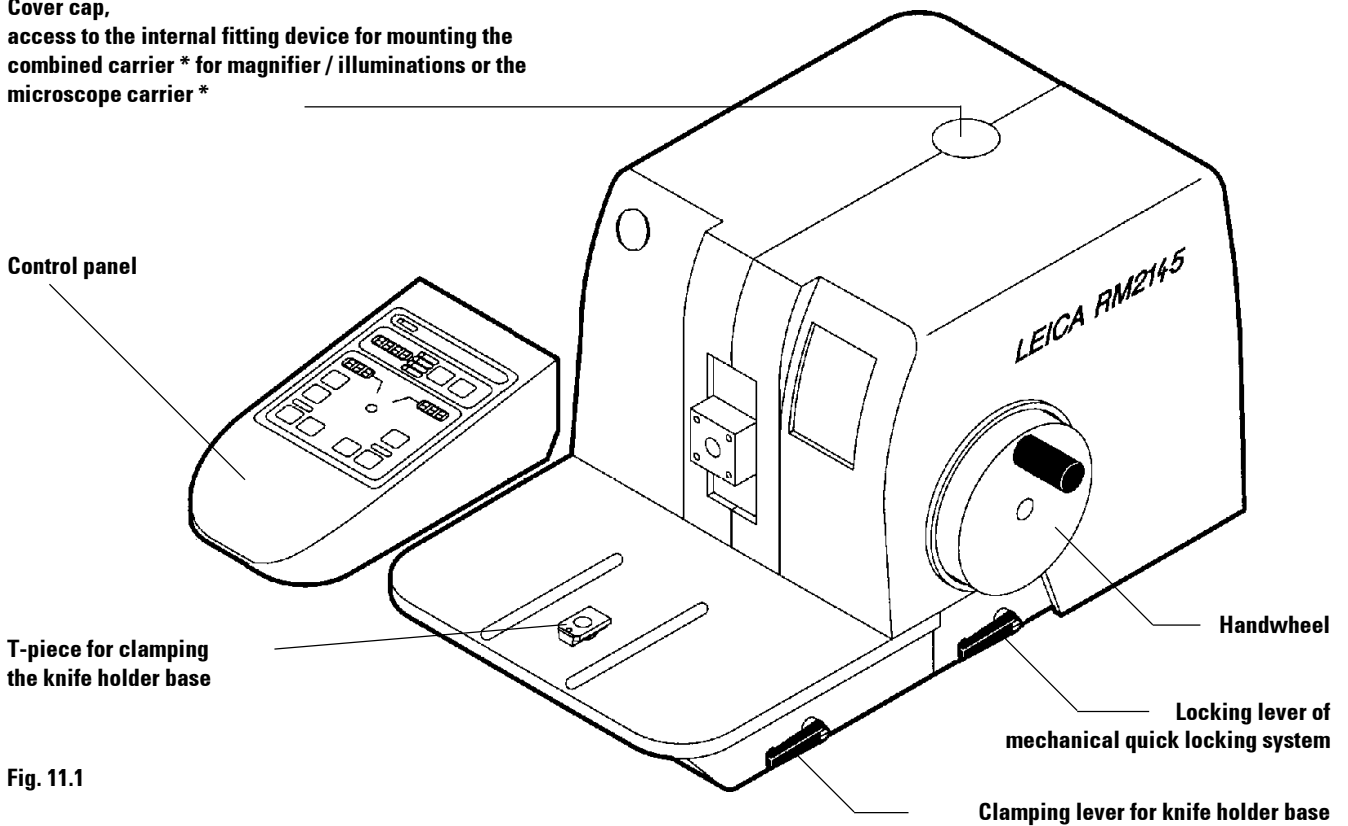

Fig. 11.1

* Optional accessories

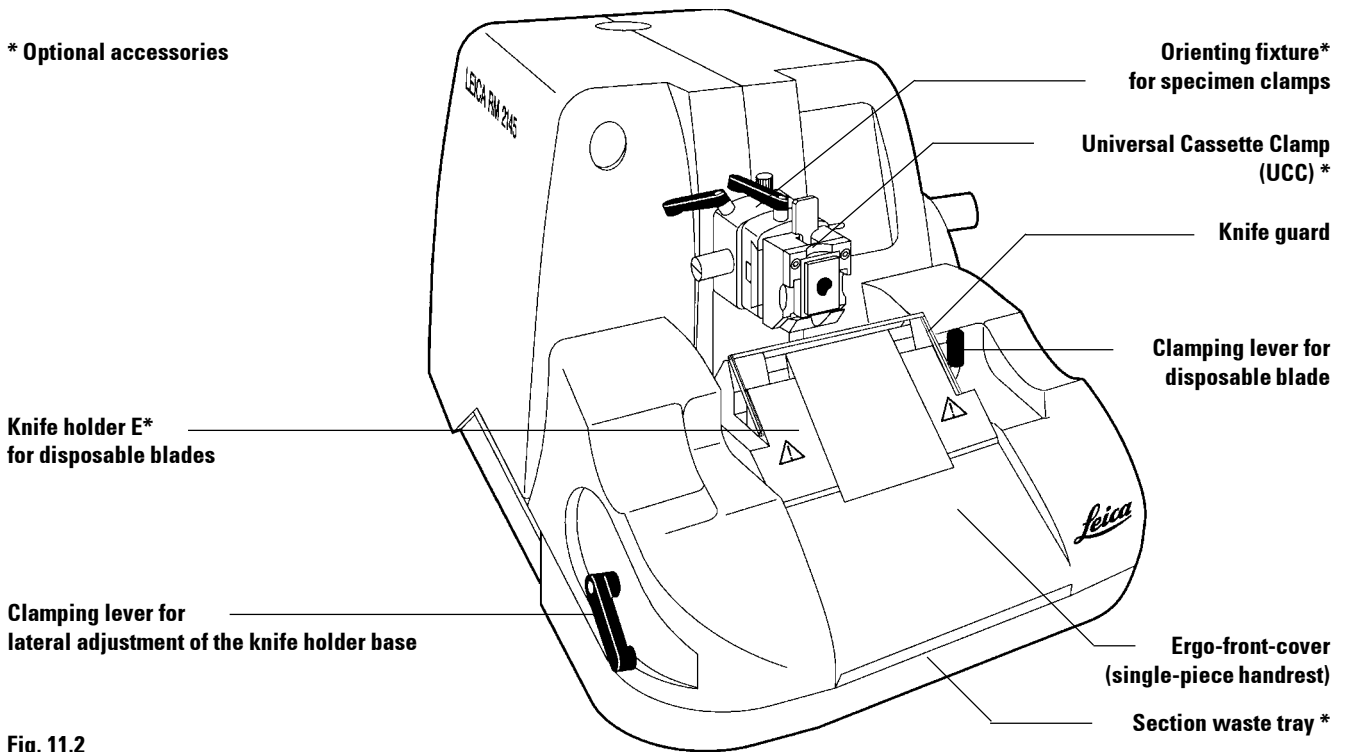



Fig. 11.2

6. Unpacking and installation

6.1 Unpacking



Upon arrival of the box, please check the Tip'n Tell indicators  on the outside of the box. If the tip of the arrow is blue, the shipment was handled improperly. In that case, please make a corresponding note on the shipping documents and check the contents for damage.

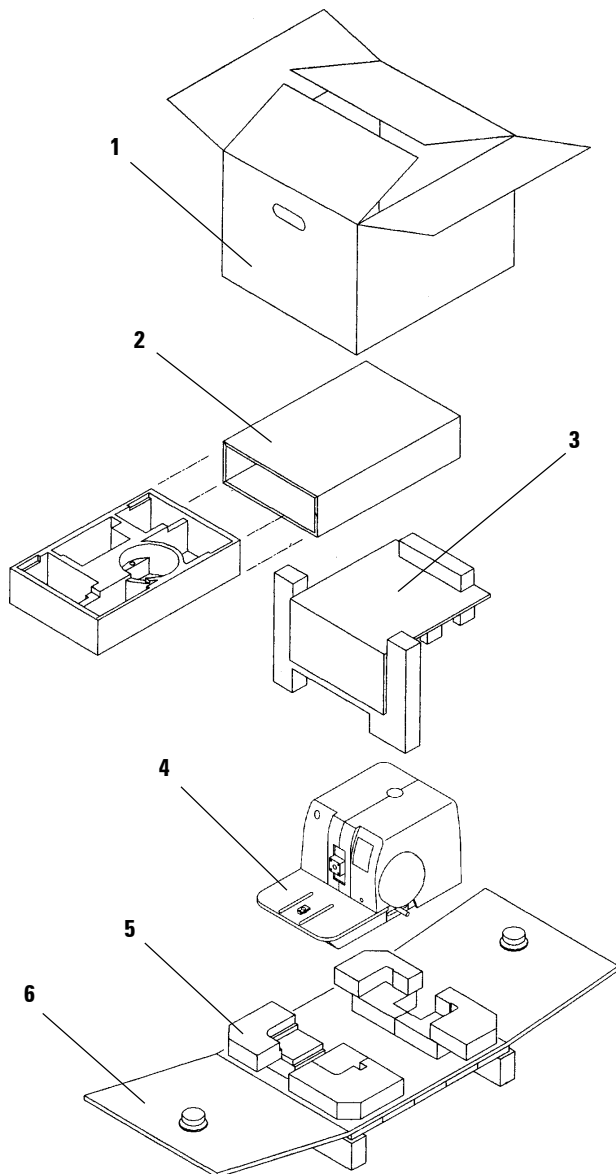

Fig. 12.1

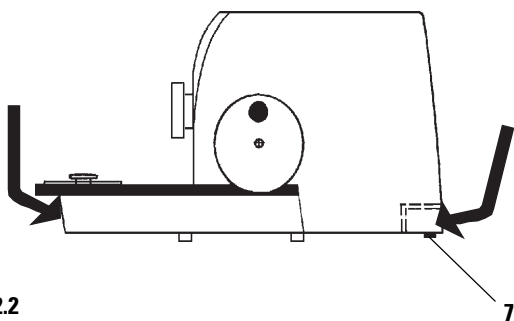

Fig. 12.2

6.1.1 Cardboard box

- Cut off the steel bands on the outside of the cardboard box.
- Open the outer cardboard box (1).
- Take out the accessory box (2) and the instruction manual.
- Remove the outer cardboard box (1) by lifting it upwards.
- Fold down the lateral parts of the inner cardboard box (6).
- Take out the fixing module (3).
- Lift the instrument (4) from the foam stabilizers (5) holding it at the front of the base plate and at the recessed grip at the rear (Fig. 12.2).
- Place the instrument on a stable laboratory bench.

The instrument is equipped with two slide faces (7) at the rear of the base plate to facilitate repositioning on the work bench.

- To move the instrument, slightly lift it at the front of the base plate and slide it to the desired location on the slide faces.

6.1.2 Wooden shipping crate

- Remove two screws (8) at the top and the bottom of each of the four sides of the crate and then take off the lid (1).
- Remove the foam bridge (2).
- Remove the side wall frame (3) lifting it upwards.
- Take out the accessory box (6).
- Lift the instrument (4) from the foam stabilizers (5) on the wooden pallet, holding it at the front of the base plate and at the recessed grip at the rear (**Fig. 12.2 - see previous page**).
- Place the instrument on a stable laboratory bench.

The instrument is equipped with two slide faces (7, **Fig. 12.2 - see previous page**) at the rear of the base plate to facilitate repositioning on the work bench.

- To move the instrument, slightly lift it at the front of the base plate and slide it to the desired location on the slide faces.

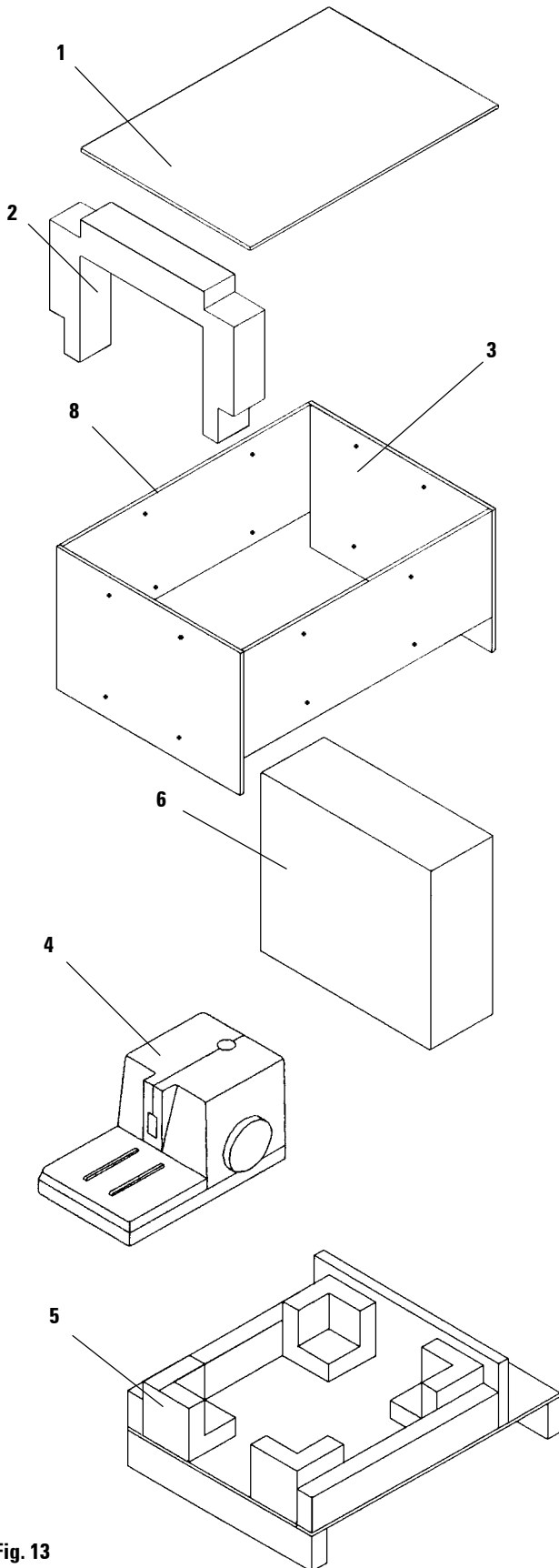

Fig. 13

6. Unpacking and installation

6.2 Assembling the handwheel



Before the instrument can be used, the handwheel has to be assembled to the main body. All required parts and tools are contained in the shipping crate.

The feather key (5) is loosely placed in the handwheel shaft (1) and secured during transport with a tie-rop.

- Remove the tie-rop.
Attention - Make sure the feather key does not fall out!
- Place the handwheel (2) onto the handwheel shaft (1) as shown.
- Tighten the screw located in the center hole of the handwheel with an Allen key, size 5 (3).
- Remove the lidding foil from the autoadhesive cover (4) and place it onto the handwheel.

To disassemble, proceed in reverse order.

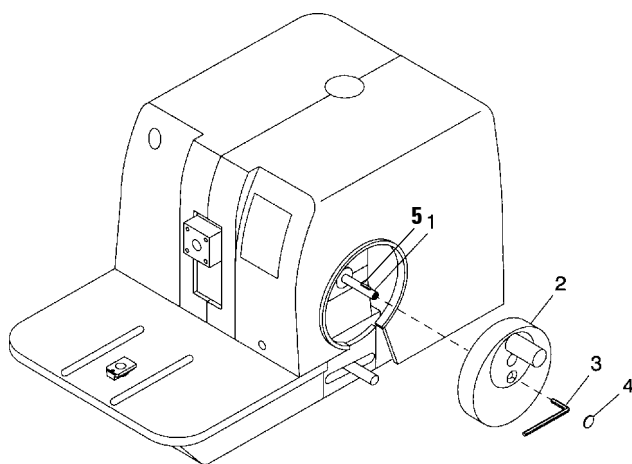

Fig. 14

6.3 Site requirements



Do not operate the instrument in rooms with explosion hazard!



To ensure trouble-free function, a minimum distance of at least 10 cm to walls and other objects must be kept on all sides of the instrument.

The installation site must fulfill the following requirements:

- stable, vibration-free laboratory bench,
- virtually vibration-free floor,
- Easy and comfortable access to the handwheel,
- Room temperature constantly between + 10 °C and + 35 °C,
- relative air humidity not exceeding 80 %.

7.1 Connecting to mains

7.1.1 Checking the voltage selector setting



Caution: The voltage selector is preset in the factory.

Before connecting the instrument to the mains power, please check whether the factory setting is identical with the local mains power in your lab!

The mains cable inlet is sealed with an adhesive tape that indicates the factory setting the instrument comes with.

Severe damage may be caused to the instrument when operating it at an incorrect voltage setting.

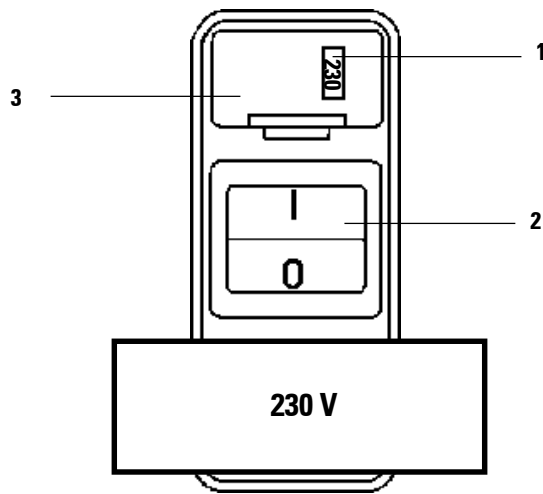

Fig. 15

The voltage selector is located in the voltage selector housing (3) above the mains switch (2) on the rear of the instrument. The actual voltage setting can be seen in a small indication window (1) in the voltage selector housing.

- Remove the adhesive tape.
- Check if the voltage selector setting that shows in the window (1) is the appropriate one for your local mains supply.

If the setting is correct, please proceed to section 7.1.3 of this manual.

If the voltage shown in the indication window does not correspond to your local mains supply, the voltage selector setting **MUST** be changed prior to connecting the instrument to the mains supply.

7. Setting up the instrument

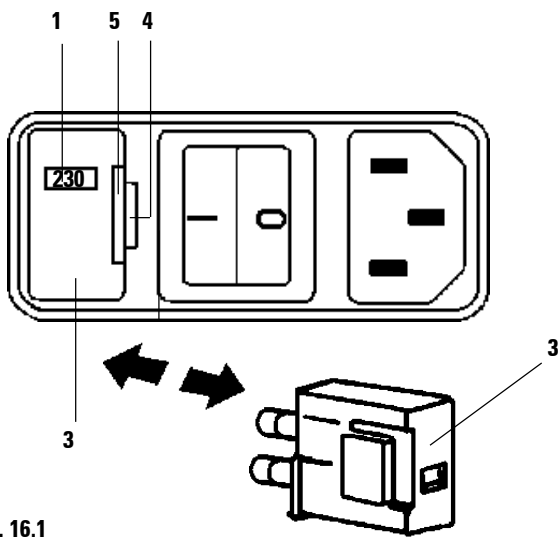

Fig. 16.1

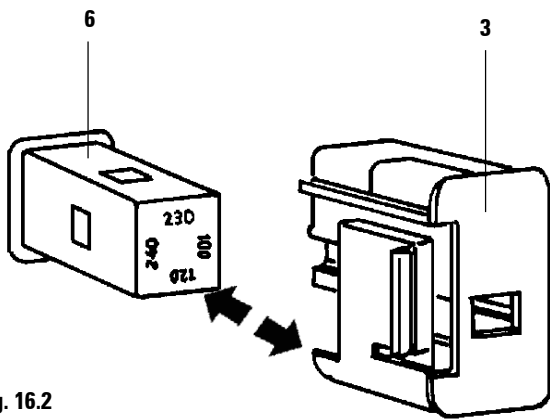

Fig. 16.2

7.1.2 Changing the voltage selector setting



Do not change the voltage selector setting, with the instrument being connected to the mains.

- Place the tip of the smaller one of the two screwdrivers into the small recess (4) of cover (5) and push very carefully, using the screwdriver as a lever, to remove the housing.
- Pull out the voltage selector housing (3).
- Remove the voltage selector (6) from the housing and reinsert it so that the appropriate value shows in the indication window (1).
- Reinsert the housing (3) together with the fuses into the instrument, push lightly to lock it in place.
- Check again whether the correct voltage shows in window (1).

7.1.3 Connecting the control panel



The connection cable of the control panel is permanently connected to the microtome.

- Insert the plug of the connection cable into the corresponding socket at the rear of the control panel.
- To secure the plug, tighten the two screws.

7.1.4 Connecting the mains cable



The instrument is delivered with a set of different, country-specific mains cables.



The instrument may only be connected to a grounded mains power outlet socket. To connect the instrument only use one of the mains cables that are supplied together with the instrument!

- Before connecting the mains cable, check if the mains switch (3) at the rear of the instrument is in the OFF position ('0').
- Select the mains cable with the appropriate plug for your local mains power outlet.
- Connect the mains cable to the socket (4) at the rear of the instrument.
- Connect the mains plug to the wall outlet.

The instrument is ready to be switched on.



In case of exposure to extreme temperature changes and high air humidity condensation may form inside the instrument. If that type of exposure has taken place, make sure to wait at least 2 hours before switching on the instrument to allow it to adapt to the local ambient temperature. Failure to allow for the required waiting time may cause severe damage to the instrument!

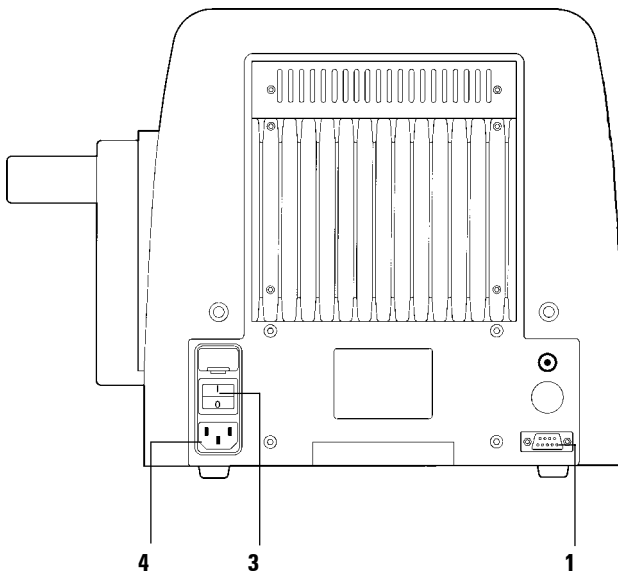

Fig. 17

7. Setting up the instrument

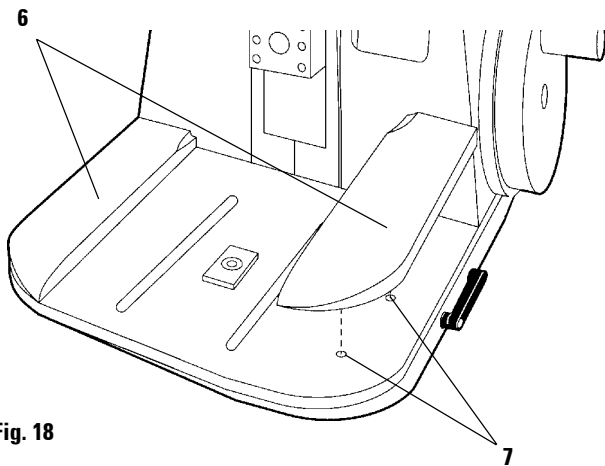

Fig. 18

7.2 Installing the arm rests

- Insert the pins on the underside of the arm rests (6) into the corresponding holes (7) of the microtome base plate as shown.

7.3 Switching on the instrument

- Switch on the mains switch at the rear of the instrument.

Switching on the mains switch is followed by a beep. The instrument initializes.

Next the software version is displayed in the four-digit display for approximately 2 seconds.

Depending on the preselected setting, one of the two three-digit displays either reads the currently selected sectioning (**SECT./ μm**) or trimming thickness (**TRIM/ μm**) - (Shown here is the section thickness).

After turning on the instrument, all displays and the LED's of all activated functions are illuminated.

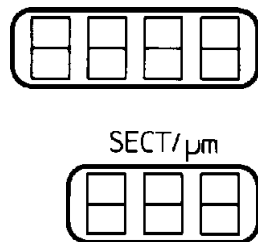

7.4 Control panel functions

All controls of the microtome are operated via the separate control panel. Only safety relevant elements, such as the mechanical handwheel quick locking system are located directly on the microtome

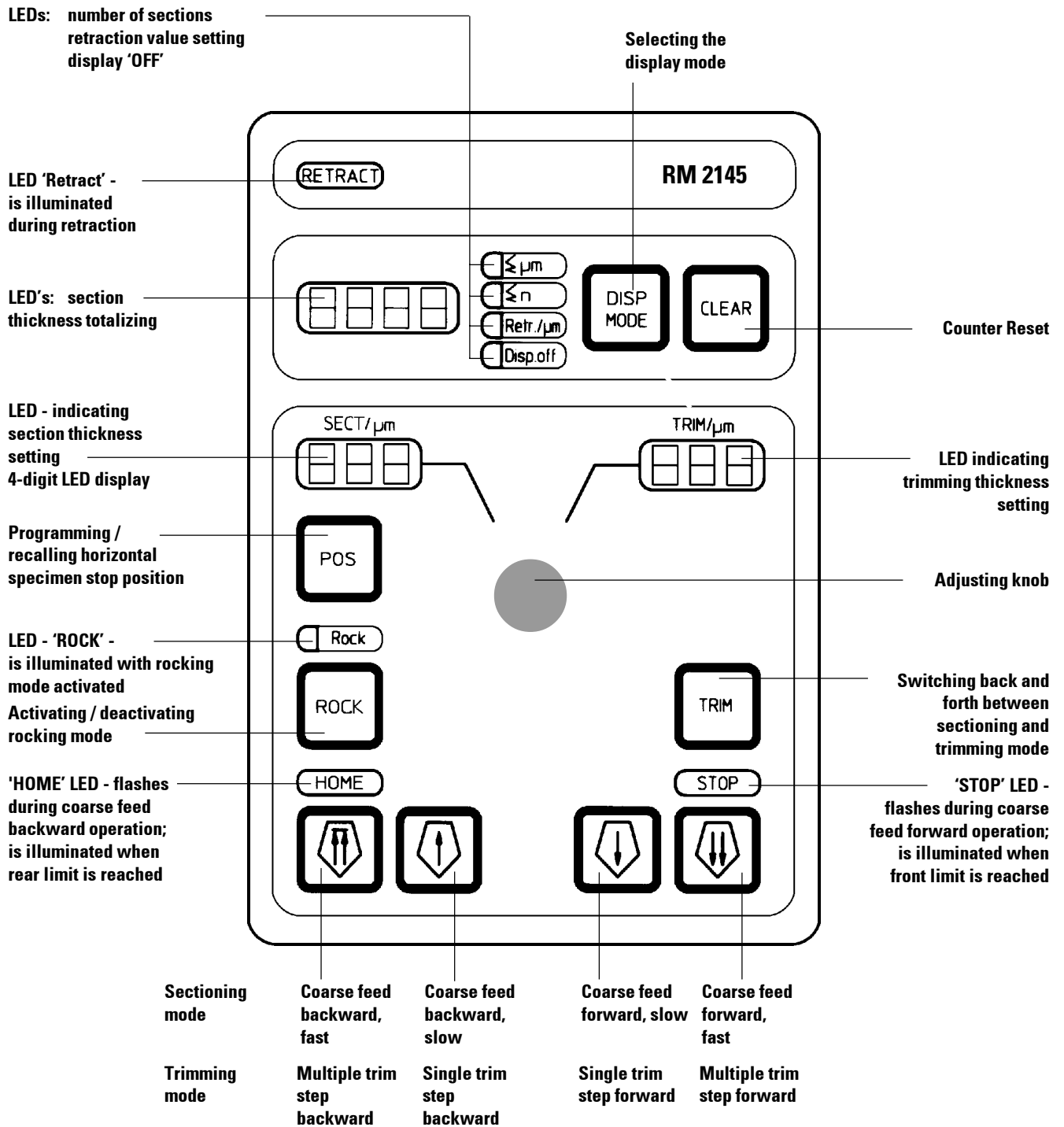
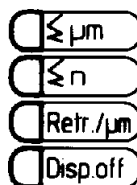
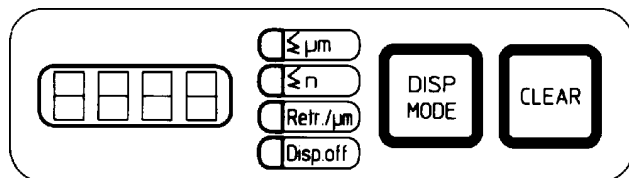
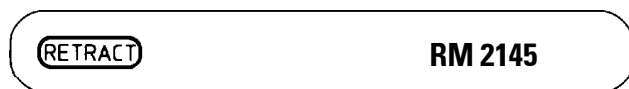

Fig. 19

7. Setting up the instrument



'Retract' indication

RETRACT (yellow) is illuminated with specimen retraction is 'ON', while the specimen is in the actual retraction phase.

4-digit LED display

The display mode of the 4-digit display can be selected as required. It can also be turned off.

Display modes:

- $\Sigma \mu\text{m}$ - Section thickness totalizing
- Σn - Number of sections
- Retr./ μm** - Retraction value setting in μm
- Disp. off** - Display OFF

The LED of the selected display mode is illuminated.

- To change the display mode, push **DISP MODE** until the LED of the desired mode is illuminated.
- Press **CLEAR** to reset section thickness totalizing and number of sections.

Of the two resettable options, only the displayed value is reset.

When switching off the instrument main switch, both section thickness totalizing and number of sections are deleted.

When selecting the horizontal specimen stop positioning mode, the positioning status is indicated on display.

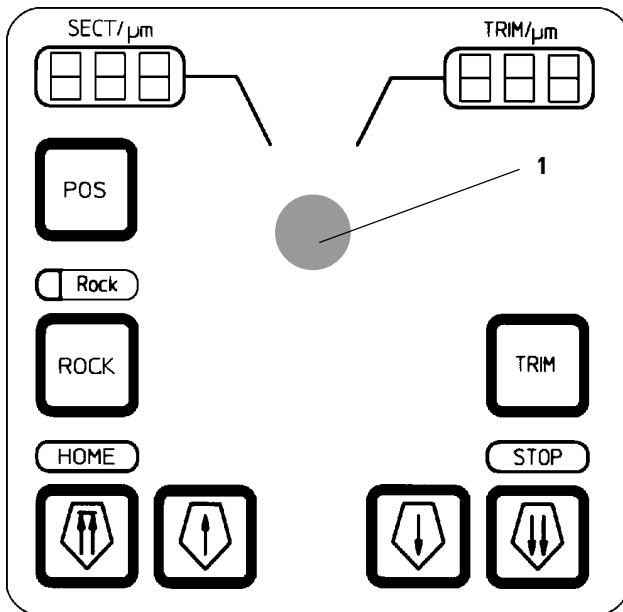

This field of the control panel includes all settings and selections for trimming and sectioning.

3-digit displays

The 3-digit display **SECT/μm** reads the selected sectioning thickness. The 3-digit display **TRIM/μm** reads the selected trimming thickness.

Adjusting knob

The adjusting knob is for adjusting all values indicated in the 4-digit and 3-digit displays.



The adjusting knob has no mechanical limit stop, i.e. it can be rotated endlessly in either direction.

Value adjusting itself is of course not endless and will only take place within the given setting ranges (e.g. section thickness setting: 0.25 - 60 μm).

Selecting the sectioning and trimming mode

- Press **TRIM** to switch back and forth between sectioning mode **SECT/μm** and trimming mode **TRIM/μm**.



Every time you press the button, the display will alternate between **SECT/μm** and **TRIM/μm**.

The sectioning indication **SECT/μm** always displays the section thickness in a range between 0.25 and 60 μm, the trimming indication **TRIM/μm** displays the trimming thickness between 1.0 and 600 μm.

7. Setting up the instrument

Selecting the section thickness

Setting range: 0.25 - 60 μm

Selectable values:

0.25 μm , 0.50 μm , 01.0 μm , 01.5 μm ,
1 μm increments from 2 to 20 μm ,
5 μm increments from 20 to 60 μm .

Turn the adjusting knob (1) to select a value within the setting range.

The current selected sectioning thickness is indicated in the 3-digit **SECT/ μm** display.

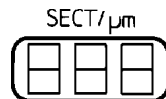

Selecting the trimming thickness

Setting range: 1 - 600 μm

Selectable values:

in 1 μm increments from 1 to 10 μm ,
in 2 μm increments from 10 to 20 μm ,
in 5 μm increments from 20 to 50 μm ,
in 10 μm increments from 50 to 100 μm ,
in 50 μm increments from 100 to 600 μm .

Turn the adjusting knob (1) to select a value within the setting range.

The current selected trimming section thickness is indicated in the 3-digit **TRIM/ μm** display.

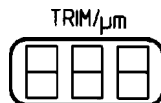

Programming a horizontal specimen stop position



This functions allows to define and save a position at a determined distance from the knife edge to which the specimen can be moved at any time by simply pressing a button.

- To program the desired horizontal stop position, press **POS** briefly.

A short beep will sound and the 4-digit display reads 'PoS'.

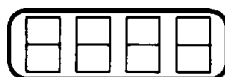

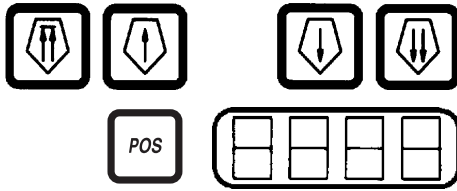

- Press one of the coarse feed buttons to move the specimen to the desired position.
- To save this position, press **POS** again until the 4-digit LED display reads '**Sto**' for saving.

The selected stop position is then saved. The instrument performs a test run, moving the specimen first to the rear limit stop (HOME) and then back to the saved horizontal stop position. This test run is performed to double-check whether the saved position is really located where it is desired.

From then on, the saved position can be approached at any time or can be altered by saving a new position.

When the instrument is switched off, the last horizontal stop position that has been saved position remains archived.

If the **POS** is released before '**Sto**' is displayed, the previously saved position is maintained.

Also, if during the backward movement (to HOME) of the test run the emergency stop is activated, the previously saved position is maintained.

Invoking the programmed stop position



If the knife holder has been repositioned since last invoking the programmed horizontal stop position, there is a risk that the specimen may collide with the knife when the specimen moves forward. In case of emergency, interrupt the specimen advance movement with the emergency stop.

2 x



- To activate the saved horizontal stop position, press **POS** twice within a short period of time.

The 4-digit LED reads "**POS**". The specimen is then moved to the desired position.

7. Setting up the instrument

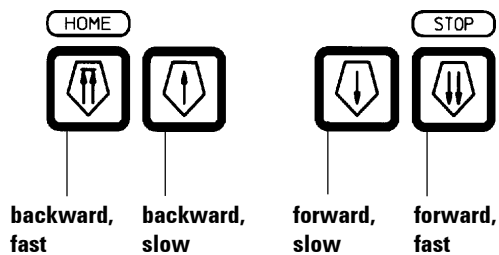

Coarse feed functions

The motorized two-speed coarse feed serves to quickly move the specimen towards and away from the knife.

When pressing the double-arrow buttons, the coarse feed speed is 900 $\mu\text{m/s}$; the single-arrow buttons activate a 300 $\mu\text{m/s}$ specimen movement speed.

The coarse feed functions are different in the sectioning (SECT./ μm) and the trimming (TRIM/ μm) mode.

Sectioning mode (SECT./ μm)

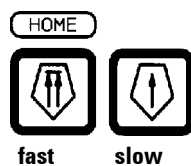

Pressing the coarse feed buttons while in the sectioning mode (SECT./ μm) a continuous specimen movement sets in and continues while the button remains pressed. The fast backward button has a lock-in function (i.e. the movement continues after the button has been released).

- To activate a fast backward travel of the specimen press the corresponding button.

Once the button has been pressed, the specimen will travel all the way to the rear limit stop position.

- To interrupt the movement, press any one of the four coarse feed buttons.
- To activate the slow backward movement, press the corresponding button.

The movement will continue, while the button remains pressed.

HOME (yellow) flashes while the sample is in motion and is illuminated continuously after reaching the rear limit.

- To start a fast or slow forward specimen advance, press the appropriate coarse feed button.

The movement will continue, while the button remains pressed.

STOP (yellow) flashes while the sample is in motion and is illuminated continuously after reaching the front limit. On reaching the front limit the instrument will also emit a beep.

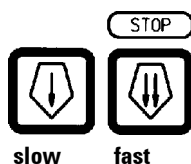

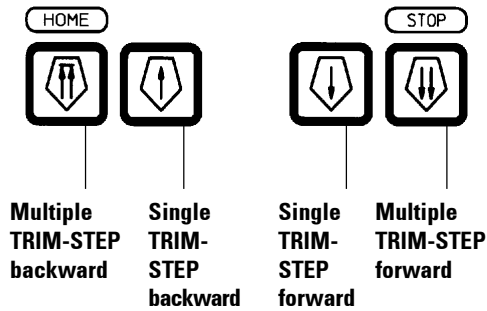

Trimming mode (TRIM/μm)



In the trimming mode, the coarse feed buttons perform the so-called TRIM-STEP function. When pressing a coarse feed button, a defined, step-by-step advance (TRIM-STEP) by the value selected in the LED TRIM/μm display and in the direction of the selected coarse feed button.

- When pressing a single-arrow coarse feed button, a single TRIM-STEP takes place in the selected direction.
- When pressing one of the double-arrow coarse feed buttons just briefly, there will also be a single TRIM-STEP in the selected direction.
- When holding down one of the double-arrow coarse feed buttons, multiple consecutive TRIM-STEPs are performed as long as the button is pressed.

Sectioning modes

Sectioning can be done either by the conventional method of one full handwheel rotation per section or in the rocking mode.

- To activate the rocking mode, press **'ROCK'**.

The 'ROCK' LED will be illuminated.

- To section, rock the handwheel back and forth over a short distance.

Every change of direction is electronically detected and translated alternately into advance and retract movements.

- To deactivate the rocking mode, press 'ROCK' again.

The 'ROCK' LED will be extinguished.

The instrument can then again be used in the conventional full-rotation mode.



7. Setting up the instrument

Specimen retraction

The specimen retraction protects both knife edge and specimen while the specimen is in the return motion to the upper starting position.

The retraction value can be set in 5 μm increments between 5 and 100 μm . It can also be deactivated, if necessary.

The selected retraction value remains archived after the instrument is switched off.

Setting the retraction value



At works, a retraction value of 10 μm is preselected.

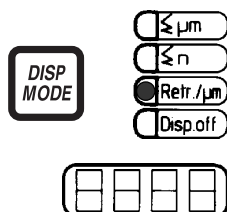

- To activate the retraction setting mode, press **DISP MODE** the necessary number of times until the LED at '**Retr./ μm** ' is illuminated.

The 4-digit display reads the currently selected value (e.g. '020' = 20 μm ; 'OFF' = DES).

- Use the adjusting knob to select the desired retraction value.
- To leave the retraction setting mode, press **DISP MODE** until the LED of the desired display mode is illuminated.

In the manual sectioning mode, after every section a retraction movement by the selected thickness value will be carried out



While the specimen is in retract motion, RETRACT (yellow) will be illuminated.

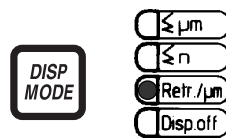

Specimen retraction ON / OFF

- To select the retraction setting mode, press **DISP MODE**, if necessary several times, until the '**Retr./μm**' LED is illuminated..

The 4-digit display reads the currently selected value (e.g. '010' = 20 μm; 'OFF' = DES).



- To activate retraction, rotate the adjusting knob clockwise, until the LED display reads the desired retraction value.
- To deactivate retraction, rotate the adjusting knob counterclockwise, until the LED display reads '**OFF**'.
- To exit the retraction setting mode, press **DISP MODE** until the LED of the desired display mode is illuminated.



When retraction is deactivated, there will be no retraction movement of the specimen after the sectioning stroke and the yellow 'RETRACT' LED will be extinguished.

7. Setting up the instrument

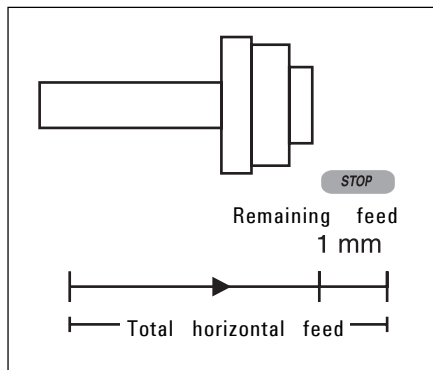
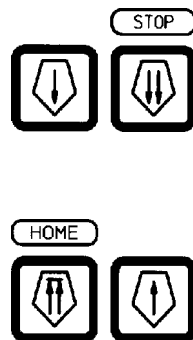

Fig. 28



Remaining horizontal feed indication

A visual and audible remaining horizontal feed indication feature advertises the user during trimming and sectioning that a horizontal feed range of about 1 mm remains before the front limit stop will be reached.

STOP (yellow) will be illuminated when reaching the remaining horizontal feed. In addition, at the same time a beep is emitted, which lasts about 2 seconds.

At that point, there is a remaining distance of 1 mm to the front limit stop. Within this remaining feed, a specimen advance via the coarse feed buttons cannot be activated any longer.

- You can continue to section.

STOP (yellow) is illuminated.

When the front limit is reached the specimen will not advance any further, i.e. sectioning automatically stops.

- To continue sectioning, move the specimen back to the rear limit stop (HOME) using the appropriate coarse feed button.



If the instrument is switched on with the specimen being located at a position within the remaining feed range, after visualizing the software version, an additional beep will sound.

To start working, the specimen has to be moved backwards by a certain distance by means of the coarse feed buttons.

Within the remaining horizontal feed range, the TRIM-STEP function is inoperational. To move the specimen backwards via the coarse feed buttons, if necessary, press TRIM to switch from TRIM/ μm to the sectioning mode SECT/ μm .

8.1 Inserting the specimen clamp

All specimen clamps available as accessories fit into the fixture for specimen clamps (see chapter 11 'Optional accessories').

The fixture for specimen clamps is available in two versions - with and without specimen orientation - which can be exchanged against each other.

The specimen orientation feature allows an easy adjustment of the specimen surface while the specimen remains clamped.

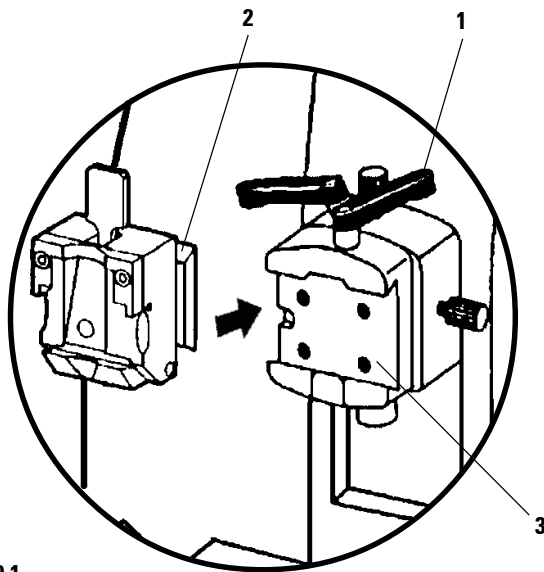

Fig. 29.1

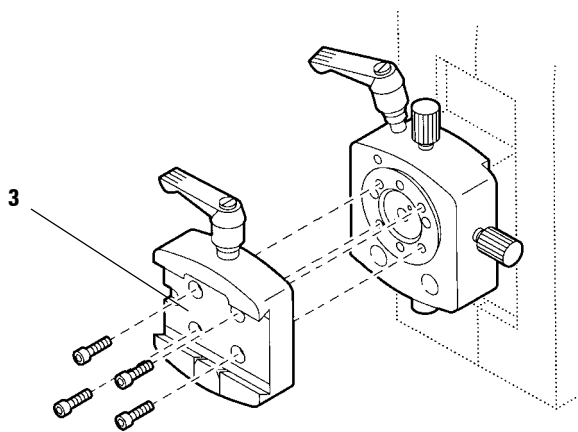

Fig. 29.2

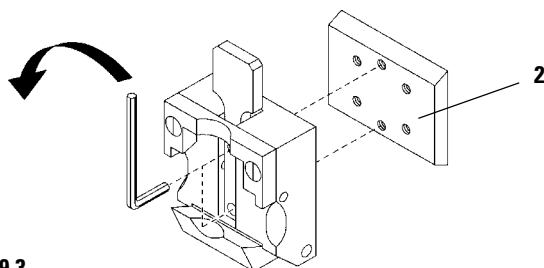

Fig. 29.3

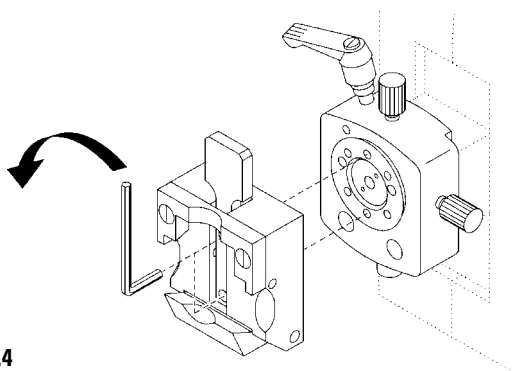

Fig. 29.4

- Rotate the handwheel to move the fixture for specimen clamps to the top of the cutting stroke. Activate the mechanical quick locking system for the handwheel.
- Release the clamping mechanism by rotating the clamping lever (1) counterclockwise.
- Insert the dovetail guide (2) of the specimen clamp from the left into the dovetail adapter (3) up to the limit stop.
- To tighten the clamping mechanism, rotate the clamping lever (1) clockwise.

8.2 Assembling the specimen clamp directly to the fixture for specimen clamps



The specimen clamps (standard clamp and Universal Cassette Clamp) can be assembled directly to the fixture for specimen clamps without placing the dovetail adapter in between.

- Rotate the handwheel to move the fixture for specimen clamps to the top of the cutting stroke. Activate the mechanical quick locking system for the handwheel.
- To remove the dovetail adapter (3) from the fixture (Fig. 29.2) detach the four screws with a no. 3 Allen key.
- To remove the dovetail guide (2) from the specimen clamp unscrew the two corresponding screws on the specimen clamp (Fig. 29.3).
- Place the specimen clamp on the fixture as shown (Fig. 29.4) and fix it with the two corresponding screws.

8. Daily routine operation

8.3 Clamping the specimen



Always clamp the specimen before clamping the knife!

Before manipulating knife or specimen/before changing specimens: always lock the handwheel!

- Rotate the handwheel to move the specimen clamp to the top of the cutting stroke.
- Lock the handwheel.
- Insert the specimen into the specimen clamp.



Please refer to chapter 11 'Optional accessories' on how to clamp the specimens into the individual specimen clamps.

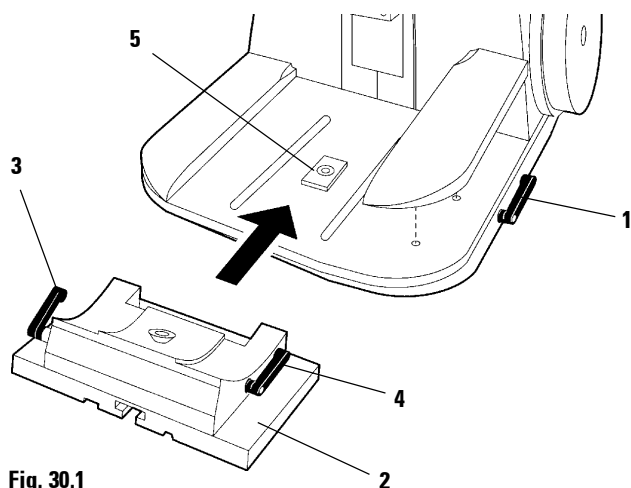

Fig. 30.1

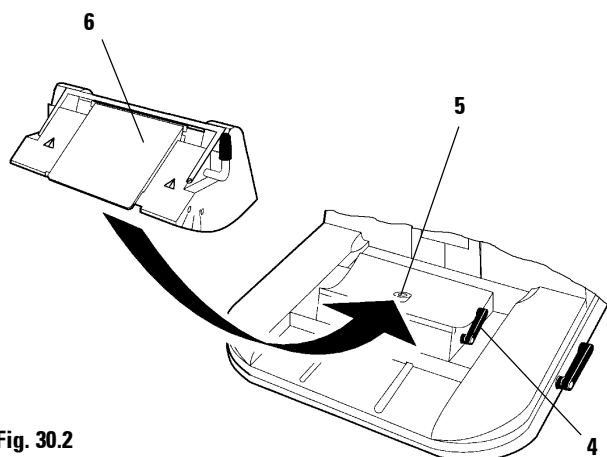

Fig. 30.2

8.4 Installing the knife holder base

- To release, turn the lever (1) counterclockwise.
- Place the universal knife holder base (2) with two clamping levers (3) and (4) onto the 'T' piece (5) of the microtome base plate.
- Turn lever (1) clockwise to tighten the knife holder base.

8.5 Installing the knife holder

- To release lever (4) rotate counterclockwise.
- Install the knife holder (6) onto the 'T' piece (5) of the knife holder base.
- Rotate lever (4) clockwise to clamp.

8.6 Inserting the knife or disposable blade



Be extremely careful when handling microtome knives and/or disposable blades! The cutting edges are extremely sharp and can cause severe injury!



Please refer to chapter 11 'Optional accessories' on how to insert knives / disposable blades into the individual knife holders.

- Insert the knife or disposable blade carefully into the knife holder and tighten the knife clamping mechanism.

8.7 Adjusting the clearance angle

The scale for the clearance angle adjustment (0°, 5° and 10°) is located on the right side of the knife holder.

A corresponding reference line for the adjustment scale is located on the right side of the knife holder base.

- To release the clamping mechanism, turn lever (1) counterclockwise.
- Adjust the clearance angle by rotating the knife holder until the index line of the desired clearance angle setting coincides with the reference line on the knife holder base (recommended clearance angle adjustment for knife holder E: 1 - 3°).
- Hold the knife holder firmly in the selected position and lock it by turning lever (1) clockwise.

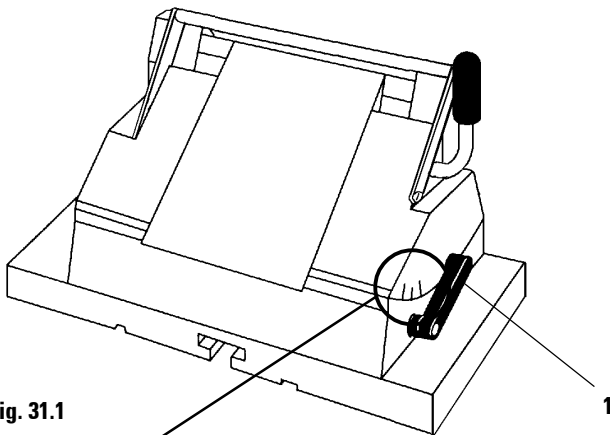

Fig. 31.1

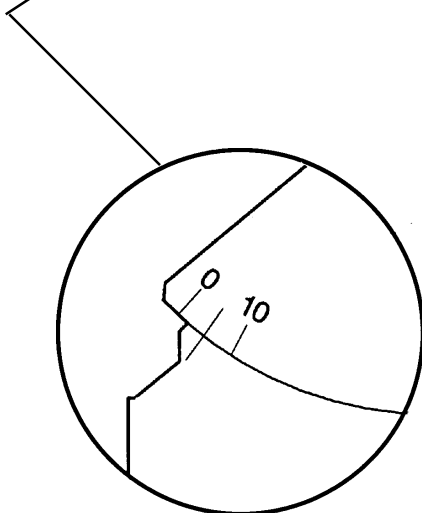

Fig. 31.2

8.8 Orienting the specimen (only with orienting specimen clamp fixture)

The specimen orientation allows a simple correction of the position of the specimen surface while the specimen remains fixed in the specimen clamp.

- Use the coarse feed buttons to move the specimen to the rear limit (HOME) position..
- Release the clamping lever on the right side of the microtome base plate and approach the knife holder base with the knife holder closely to the specimen.



Never attempt to orient the specimen while the instrument is in the retraction phase (i.e. while the yellow RETRACT indication is illuminated)! Prior to the next section, the specimen will advance by the retraction value plus the selected section thickness! There is danger that specimen and knife will be damaged.

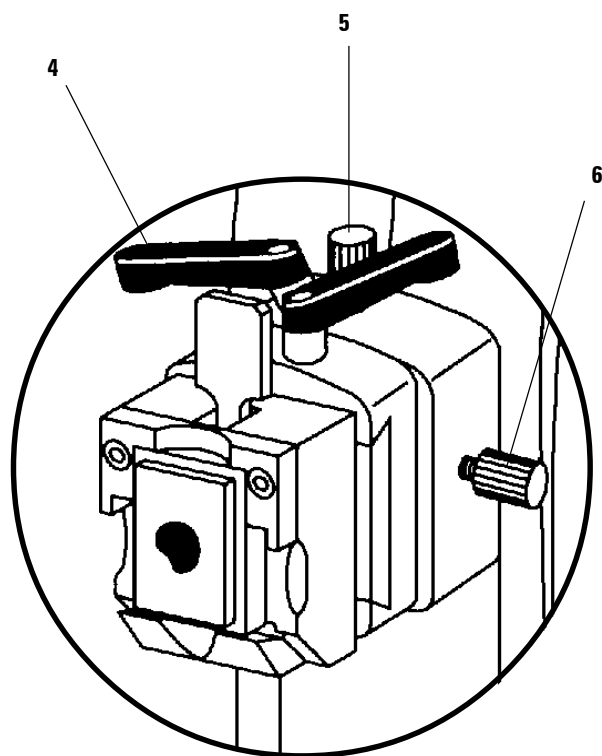

Fig. 32

- Rotate the handwheel to position the specimen clamping system at the top of the cutting stroke and activate the handwheel locking system.
- To release the clamping mechanism rotate the eccentric bolt (4) counterclockwise.
- Rotate adjusting screw (5) to orient the specimen in north-south direction. Use adjusting screw (6) to orient it in east-west direction.
- To clamp the specimen in the selected orientation, turn eccentric bolt (4) clockwise.



When using the large version of the standard specimen clamp (50 x 55 mm) the specimen orientation of 8° in north-south direction cannot be used fully. The north-south orientation angle is limited to about 4°.

8.9 Trimming

- Select the trimming mode '**TRIM/μm**'.
- Select the desired trimming section thickness or check the already selected thickness setting for appropriateness.
- Pull the section waste tray (optional accessory) out from under the microtome base plate.
- Remove the knife guard from the knife edge.
- Unlock the handwheel.
- Use the TRIM STEP mode to approximate the specimen to the knife / disposable blade.
- Trim the specimen by rotating the handwheel clockwise or select the rocking mode '**ROCK**' to trim the specimen by moving the handwheel back and forth over a short distance.
- Stop trimming when reaching the desired sectioning level of the specimen.

8.10 Sectioning



Always rotate the handwheel evenly. Adjust the rotation speed to the hardness of the specimen. Harder specimens should be sectioned at a lower speed.

- Select the sectioning mode '**SECT/μm**'.
- Select the desired sectioning section thickness or check the already selected thickness setting for appropriateness.
- For sectioning do not use the same area of the knife edge that you have previously used for trimming.

For that purpose, adjust the knife edge laterally by repositioning the knife holder on the knife holder base with lateral adjustment option. If you work with a knife holder system without lateral adjustment, reposition the knife / blade itself within the knife holder.
- Select conventional sectioning or rocking mode ('**ROCK**').
- To section, rotate the handwheel evenly in a clockwise direction or (in rocking mode) back and forth.
- Prepare the sections.

8. Daily routine operation

8.11 Changing specimens and/or pausing



Before manipulating knife or specimen /before changing specimens and during breaks: always lock the handwheel and cover the knife edge with the knife guard!

- Rotate the handwheel to position the specimen at the upper end of the cutting stroke activate the mechanical handwheel locking.
- Cover the knife edge with the knife guard.
- Remove the specimen from the specimen clamp - insert a new specimen if desired.

8.12 Finishing daily routine



Before manipulating knife or specimen / before changing specimens and during breaks: always lock the handwheel!

- Rotate the handwheel to position the specimen at the upper end of the cutting stroke activate the mechanical handwheel locking.



Be extremely careful when handling microtome knives and/or disposable blades! The cutting edges are extremely sharp and can cause severe injury!

Never place a knife anywhere with the cutting edge facing upwards!

Never leave knives or knife holders with a knife / disposable blade inserted someplace unprotected!

Always store knives in their knife case when not in use!

Never try to catch a falling knife!

- Remove the blade from the knife holder and insert it in the receptacle at the bottom of the dispenser, or remove the knife from the knife holder and put it back in the knife case.
- Remove the specimen from the specimen clamp.
- Push all section debris into the section waste tray (optional accessory) and empty the tray.
- Switch off the instrument main switch.
- Clean the instrument (see chapter 10 'Cleaning').

9.1 Instrument malfunctions



Certain instrument malfunctions appear on the 4-digit LED display or are indicated through illuminated LED's on the control panel.

9.1.1 Error message 'E-1'



If this message follows the software version indication after switching on the instrument, a loss of parameters has occurred.

- Press any key.

All parameters are then set back to the default values.

You can continue with your normal working routine.

- However, do make sure whether the settings you selected earlier are still correct and make changes if necessary.

9.1.2 HOME and STOP are illuminated simultaneously



This indicates a failure to detect the limit positions HOME and STOP.

This problem can only be corrected by Leica Technical Service..

9. Trouble shooting

9.2 Potential sources of errors - elimination

Problem	Cause	Corrective action
Thick/thin sections The section thickness varies from one section to another. In extreme cases, sections are skipped meaning that a section is not obtained.	<ul style="list-style-type: none">- Insufficient knife inclination; consequently the clearance angle is too small.- Insufficient clamping of specimen and/or knife.- Blunt knife.	<ul style="list-style-type: none">- Systematically try several clearance angle adjustments, until the optimum angle is found.- Check if all levers are locked and screws are tightened on the specimen and knife holder systems. Retighten the levers and screws if necessary.- Use a different part of the knife edge or use a new knife.
Compressed sections The sections are extremely compressed, wrinkled or jammed together.	<ul style="list-style-type: none">- Blunt knife.- Specimen too warm.- Clearance angle too big.- Sectioning speed too high.	<ul style="list-style-type: none">- Use a different part of the knife edge or use a new knife.- Precool the specimen on a cold plate.- Cool the specimen in iced water immediately before sectioning.- Clearance angle adjustment; systematically decrease the clearance angle until the optimum adjustment is obtained.- Select lower sectioning speed.
The knife "rings" on the cutting stroke when sectioning hard specimens. Sections exhibit scratches and chatter marks.	<ul style="list-style-type: none">- Sectioning speed too high.- Clearance angle too big.- Insufficient clamping of specimen and/or knife.	<ul style="list-style-type: none">- Select lower sectioning speed.- Clearance angle adjustment; systematically decrease the clearance angle until the optimum adjustment is obtained.- Check if all levers are locked and screws are tightened on the specimen and knife holder systems. Retighten the levers and screws if necessary.

9.3 Malfunctions - sources and elimination

Problem	Possible cause	How to correct it
No display indication, no response to push button activation after switching on.	<ol style="list-style-type: none"> 1. Mains cable not properly connected 2. Mains fuses defective. 3. Cable of control panel not properly connected. 	<ol style="list-style-type: none"> 1. Check mains cable connection 2. Exchange the mains fuses (see chapter 11). 3. Check connection of control panel cable.
LED reads 'E-1' after switching on.	<ol style="list-style-type: none"> 1. Spike in mains power supply caused loss of set parameters. 	<ol style="list-style-type: none"> 1. Press any button. Check settings, correct if necessary
LED repeatedly reads 'E-1' after switching on.	<ol style="list-style-type: none"> 1. Lithium battery exhausted (life time approx. 7 years) 	<ol style="list-style-type: none"> 1. Check settings - correct if necessary. Work can be continued. Have battery exchanged as soon as possible by Technical Service.
No specimen feed.	<ol style="list-style-type: none"> 1. End of remaining horizontal feed has been reached. 2. Specimen was already in remaining horizontal feed zone when switching on the instrument. 	<ol style="list-style-type: none"> 1. Move specimen backwards with coarse feed button. 2. Move specimen backwards with coarse feed button.
Specimen, while in remaining horizontal feed area, can not moved backwards via the coarse feed buttons.	<ol style="list-style-type: none"> 1. TRIM-STEP (display reading: TRIM//μm) still activated. 	<ol style="list-style-type: none"> 1. To deactivate TRIM-STEP mode, press TRIM to change to 'SECT//μm' display reading; move specimen backwards with coarse feed button.
HOME and STOP are illuminated simultaneously.	<ol style="list-style-type: none"> 1. Instrument fails to recognize limit stop positions. 	<ol style="list-style-type: none"> 1. Call Technical Service

10. Cleaning



Before cleaning, lock the handwheel, switch the instrument off and pull the mains plug!

Only use mild household cleaners / soap for cleaning.

The varnish paint coat of the instrument is not resistant to acetone or xylene!

Make sure that no liquids get into the interior of the instrument while cleaning!

- Remove sectioning debris with a dry brush.
- Pull out the section waste tray to empty.
- Remove the arm or hand rests (optional accessories) for cleaning.
- Remove knife holder and knife holder base.
- Clean the instrument with a damp (not wet!) cloth.



After cleaning wait for the instrument to be completely dry before switching it back on!

11.1 General maintenance instructions



Only authorized Leica service engineers may open the instrument for maintenance and repair work!

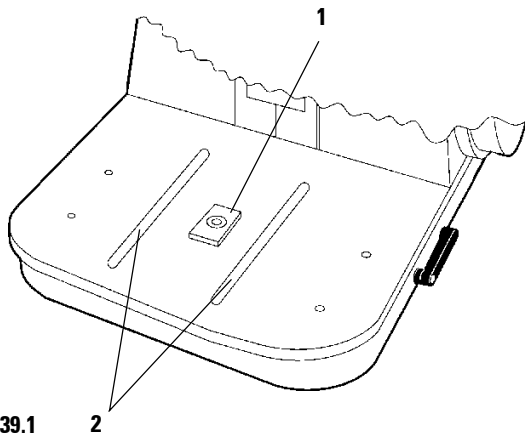

Fig. 39.1

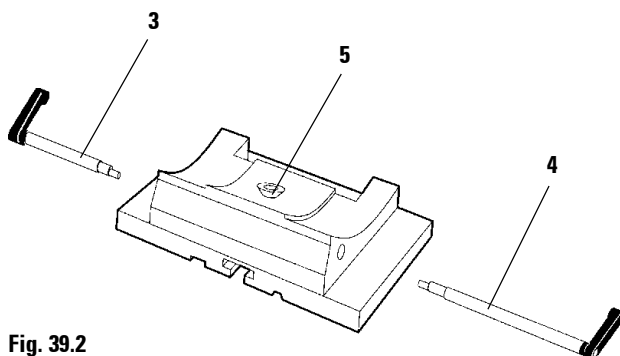

Fig. 39.2

The microtome is virtually maintenance-free. However, to ensure smooth and trouble-free operation of the instrument over a long period of time, we recommend the following preventive maintenance steps:

- Have the instrument inspected once a year by an authorized Leica Technical Service engineer.
- Ask for a Service Contract after the warranty period expires.
- Clean the instrument on a daily basis.
- Once a month, lubricate the following parts with microtome oil no. 405 which comes as part of the standard delivery (1 - 2 drops are sufficient):
 - 'T' piece (1) on the microtome base plate,
 - Guides (2) for the knife holder base on the microtome base plate,
 - clamping levers (3) and (4) on the right and left side of the knife holder base,
 - 'T' piece (5) on the knife holder base.
- Remove dust from the ventilation slits at the rear of the instrument with a brush or vacuum cleaner.
- Never attempt any repairs on the instrument yourself since this will invalidate the warranty.

11.2 Adjusting the spring lever system

When using different specimen clamps and samples of various sizes and weights, it may be necessary to readjust the spring lever system accordingly.

How to check correct adjustment

- Fix the specimen clamp with the sample.
- Turn the handwheel to position the specimen clamping head at half the height of the vertical stroke.

If the specimen head remains in this position without travelling upward or downward, the adjustment is correct.

Readjustment will be required if the specimen head slightly rises or drops.

How to readjust

The adjustment is made with the screw that is accessible through the hole on the underside of the microtome base plate, after having removed the section waste tray if used, by means of the screw driver provided.

- If the specimen head slightly **rises**, turn the screw **counterclockwise** completing two or three full rotations.
- If the specimen head slightly **drops**, turn the screw **clockwise** completing two or three full rotations.

Check for correct adjustment after each adjusting step. Repeat the adjustment several times if required.

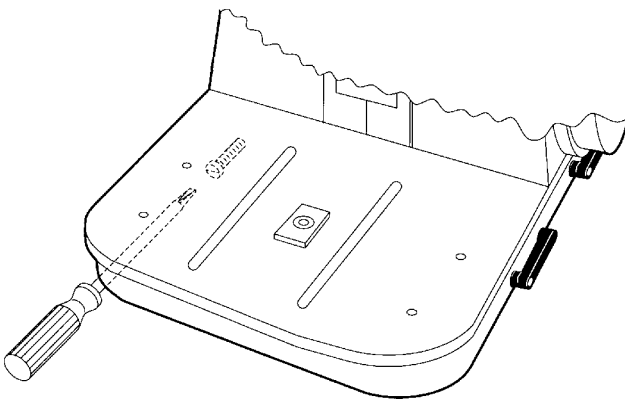

Fig. 40

11.3 Replacing the fuses



Before exchanging the fuses, switch the instrument off and pull the mains plug!
When exchanging fuses, only use replacement fuses with the same specification as the original ones. - Refer to chapter 4 'Technical data' for the correct specifications.

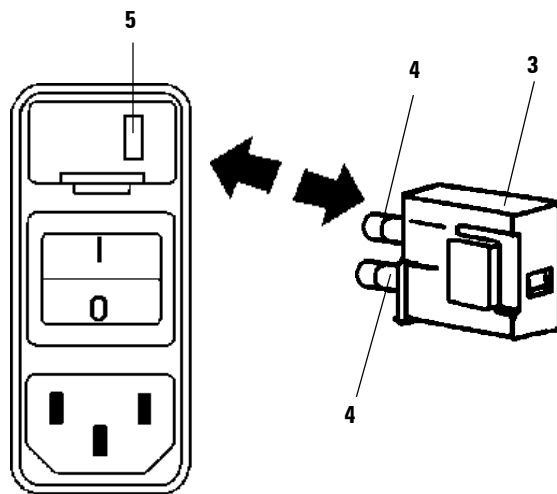

Fig. 41

The mains fuses are located in the voltage selector housing (3).

- Remove the voltage selector housing (3) (see chapter 7.1.2 'Changing the voltage selector setting').
- Remove the fuses (4).
- Insert new fuses of the same technical specification.

The selected voltage setting shows in the small indication window (5) in the voltage selector housing.

- Reinsert the housing together with the fuses into the instrument, push lightly to lock it in place.
- Check again whether the correct voltage shows in window (5).

12. Optional accessories



All specimen clamps can be used in combination with both the orienting and non-orienting specimen clamping system.

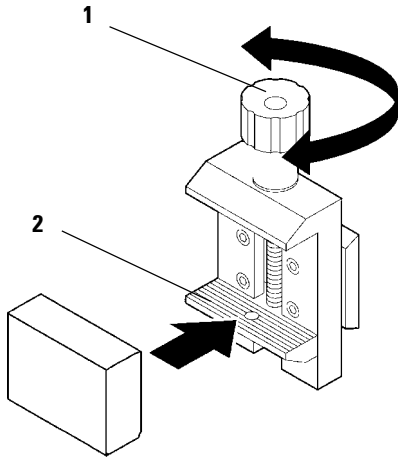

Fig. 42.1

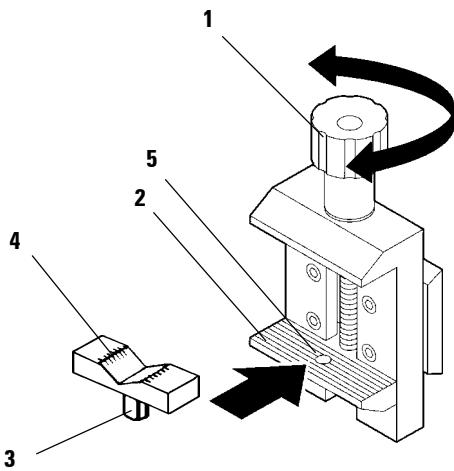

Fig. 42.2

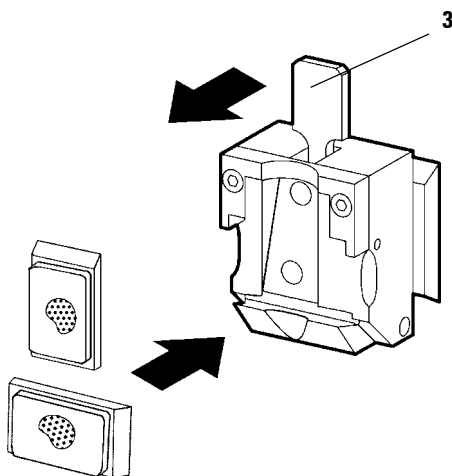

Fig. 42.3

12.1 Specimen clamps and holders

12.1.1 Standard specimen clamp

The standard specimen clamp is available in two sizes: 40 x 40 mm and 50 x 55 mm.

It is designed for direct clamping of rectangular blocks. In addition, it accommodates the foil clamps.

- Turn the knurled knob (1) counterclockwise to move the movable jaw (2) downward.
- Mount the sample as required.
- Turn the knurled knob (1) clockwise to move the movable jaw (2) upward against the fixed jaw to securely clamp the sample.

12.1.2 Vee insert

The vee insert is mounted in the hole provided in the lower movable jaw of the standard specimen clamp. This enables to clamp round specimens in the standard specimen clamp.

- Turn the knurled knob (1) counterclockwise to move the movable jaw (2) downward.
- Insert the pin (3) of the vee insert (4) in the hole (5) of the lower jaw (2).
- Mount the sample as required.
- Turn the knurled knob (1) clockwise to move the movable jaw (2) with the vee insert (4) upward against the fixed jaw to securely clamp the sample.

12.1.3 Universal cassette clamp

The universal cassette clamp (UCC) is designed to for horizontal or vertical clamping of all kinds of commercial cassettes.

- Pull the lever (3) to the front.
- Mount the cassette horizontally or vertically as required.
- Release the lever (3) to secure the cassette in position.

12.1.4 Foil clamp - Type 1

This foil clamp is appropriate both for clamping very small foil pieces and flat, angular samples. It is mounted in the standard specimen clamp.

Clamping of foil pieces

- Move the movable jaw (3) to the right or left as required by turning the set screw with an Allen key size 4 (6).
- Place the foil (2) between the movable jaw (3) and the fixed jaw (4).
- To clamp the foil, screw the movable jaw (3) against the fixed jaw (4) by using the Allen key (6).
- Insert the foil clamp in the standard specimen clamp as shown.
- Turn the knurled knob (1) clockwise to securely clamp the foil clamp in the standard specimen clamp.

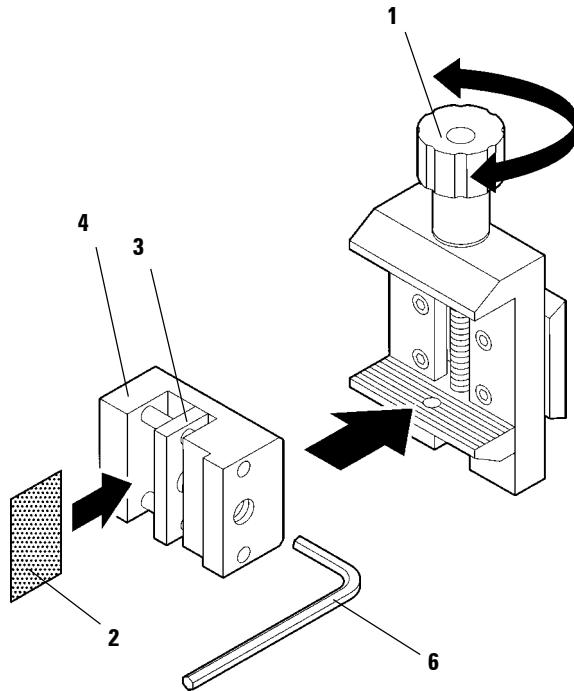

Fig. 43.1

Clamping of flat samples

To clamp flat samples, replace the long set screw (5) with the short set screw (7) provided with the foil clamp.

- Unscrew the long set screw (5) on the left with an Allen key size 4.
- Screw the short set screw (7) in the hole on the right.
- Place the sample (2) between the movable jaw (3) and the fixed jaw (4).
- To clamp the sample, screw the movable jaw (3) against the fixed jaw (4).
- Insert the foil clamp in the standard specimen clamp as shown.
- Turn the knurled knob (1) clockwise to securely clamp the foil clamp in the standard specimen clamp.

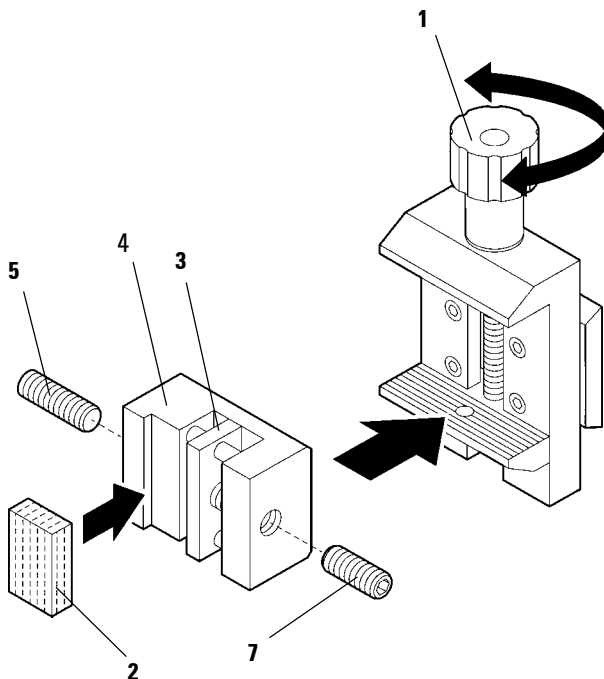

Fig. 43.2

12. Optional accessories

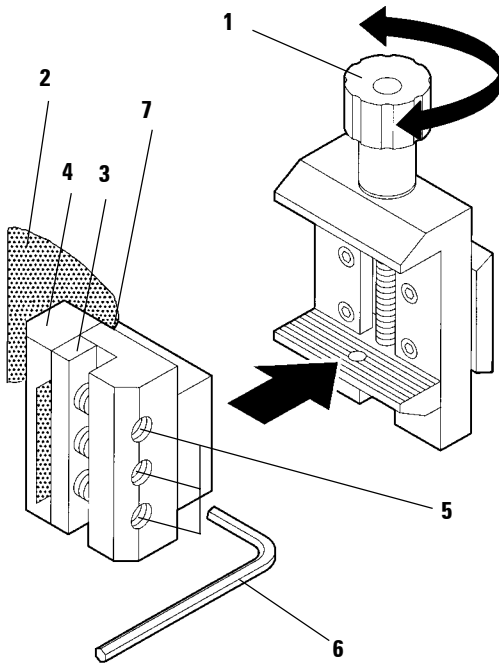

Fig. 44.1

12.1.5 Foil clamp - Type 2

This foil clamp is appropriate for large foil ribbons and is mounted in the standard specimen clamp.

- To open the jaws (3) and (4) lightly loosen the 3 screws (5) with an Allen key size 4 (6).
- Insert the foil (2) from behind to position it between the movable jaw (3) and the fixed jaw (4).
- To clamp the foil, first tighten the screw (5) in the middle and then the other two screws with the Allen key.
- Place the foil clamp in the standard specimen clamp so that the bevelled surface (7) on the back of the foil clamp points to the right or left.
- Turn the knurled knob (1) clockwise to securely clamp the foil clamp in the standard specimen clamp.

12.1.6 Holder for round specimens

The holder for round specimens is designed to accommodate cylindrical samples. Inserts for specimens of 6, 15 and 25 mm diameter are available.

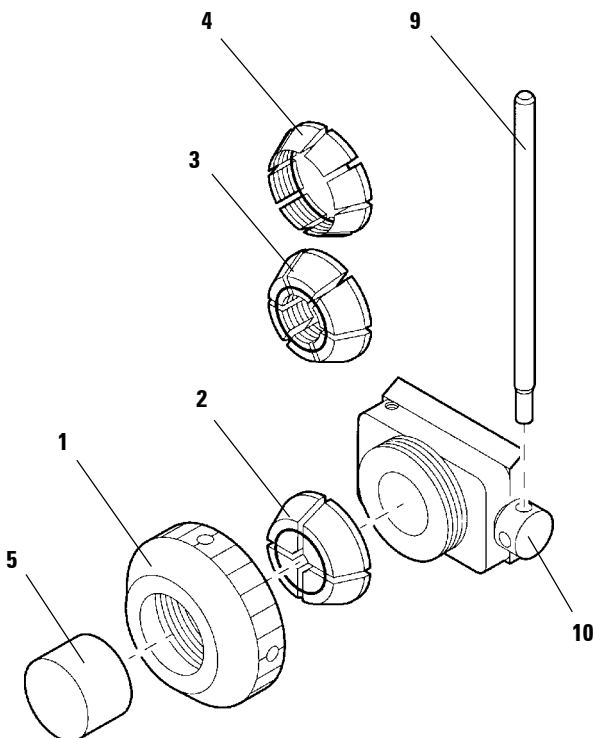

Fig. 44.2

- To mount the required insert (2, 3, 4) turn the clamping ring (1) counterclockwise and remove.
- Place the insert (2), (3) or (4) in the clamping ring (1) and fix the clamping ring (1) by turning it clockwise.
- To mount the specimen, turn the clamping ring (1) counterclockwise, mount the sample (5) and fix by turning the clamping ring clockwise.
- To orient the sample, put the pin (9) in one of the holes (10) and turn counterclockwise.
- To fix the orientation, put the pin (9) again in one of the holes (10) and turn clockwise.

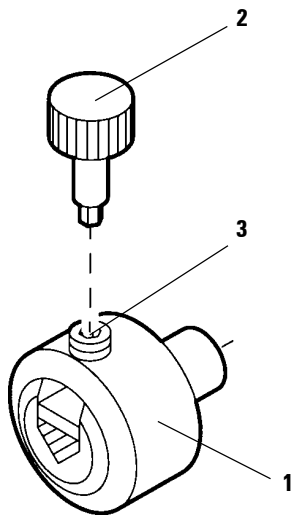

Fig. 45.1

12.1.7 EM specimen holders

The EM specimen holders are designed for very small specimens. Two versions are available: flat specimen holder (**not illustrated**) and universal specimen holder (**1**).

Both specimen holders can be mounted in the segment arc or in the non-orienting holder for EM specimen holders.

Clamping the specimen

- Introduce the special wrench (**2**) in the hole (**3**) and open the clamping jaws with the special wrench.
- Place the specimen between the jaws.
- Clamp the specimen by tightening with the special wrench.

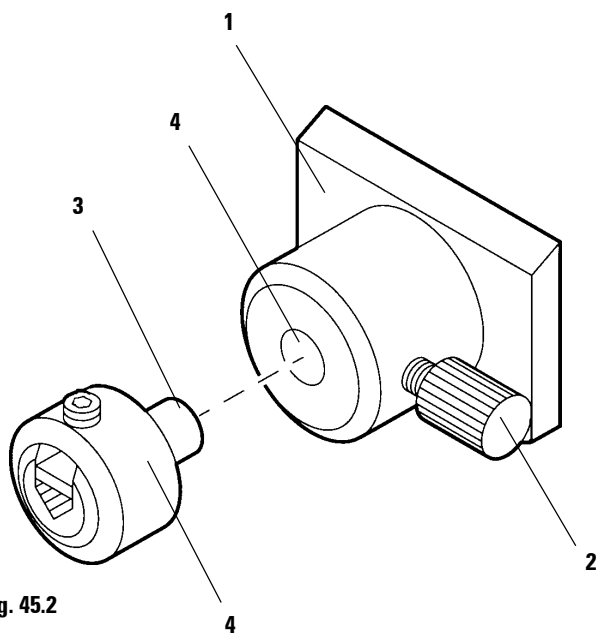

Fig. 45.2

12.1.8 Non-orienting holder for EM specimen holders

The non-orienting holder for EM specimen holders (**1**) is mounted in the dovetail adapter like a specimen clamp.

- To open, turn the knurled knob (**2**) counterclockwise.
- Introduce the pin (**3**) of the EM specimen holder (**4**) in the hole (**5**).
- Turn the knurled knob (**2**) clockwise to clamp the EM specimen holder.

12. Optional accessories

12.2 Universal knife holder bases



Both universal knife holder bases are available in two versions. The version with short clamping levers is used with the two arm rests.

The version with long clamping levers is used in combination with the handrest (see 12.8).

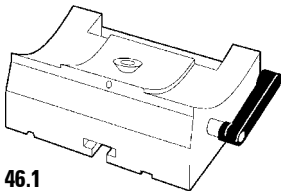

Fig. 46.1

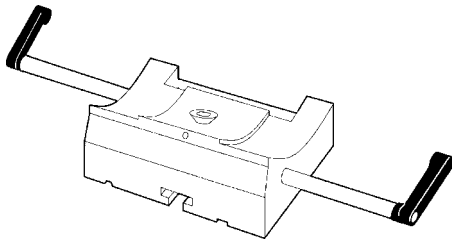

Fig. 46.2

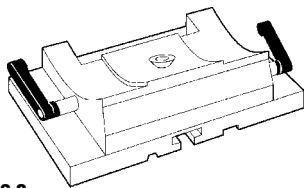

Fig. 46.3

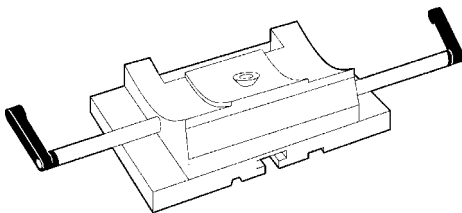

Fig. 46.4

12.2.1 Knife holder base without lateral displacement

The universal knife holder base without lateral displacement function can be repositioned on the microtome base plate only in north/south direction.

12.2.2 Knife holder base with lateral displacement

The universal knife holder base with lateral displacement function consists of two parts and can be repositioned on the microtome base plate both in north/south and in east/west direction.

12.2.3 Repositioning the knife holder base

North/South

North/South displacement enables the approach of the knife holder to the sample as close as possible.

- To release, turn the clamping lever **(1)** on the right side of the microtome base plate counterclockwise.
- Reposition the knife holder together with the knife holder base forward or backward as appropriate.
- To clamp, turn the clamping lever **(1)** clockwise.

East/West (12.2.2 only)

The lateral displacement feature of the knife holder base enables the use of the entire length of the blade or knife eliminating the need for readjusting the knife holder.

- To release, turn the clamping lever **(2, not visible)** on the left of the knife holder clockwise.
- Reposition the knife holder together with the knife holder base sideways as required.
- To secure, turn the clamping lever **(2)** counterclockwise.

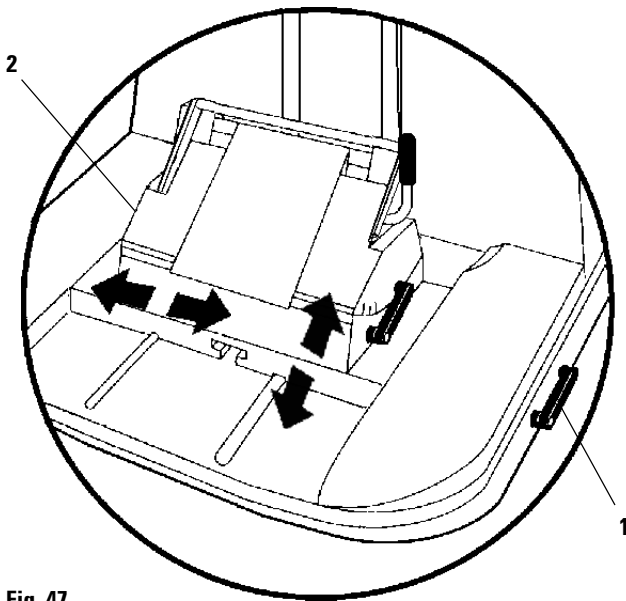

Fig. 47

12.3 Knife holders

12.3.1 Knife holder N

This knife holder is designed for standard steel and tungsten carbide knives, profile c and d, up to 16 cm long. In addition, it is appropriate for various blade rails for disposable blades, which are inserted in the holder like a knife.

The knife can be repositioned in height. This enables the use even of frequently resharpened knives.

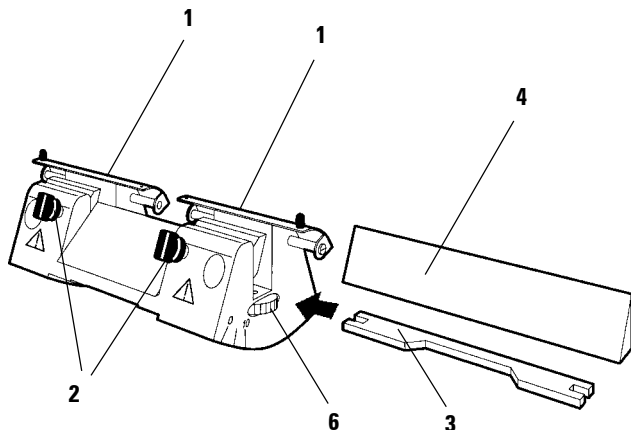

Fig. 48.1

Mounting the knife support bar

- Push the knife guard (1) to the middle.
- Place the knife support bar (3) as shown on the height adjustment screws (not visible), ensuring that the flat top ends of the height adjustment screws are seated in the slots at both ends of the knife support bar.

Inserting the knife

- Turn the knurled wheels (6) on the right and left of the knife holder in opposite directions to the front to move the knife support bar via the height adjustment screws to the lowest position, to prevent damage to the cutting edge while inserting the knife.
- Unscrew the knife clamping screws (2) counter-clockwise as far out as possible.
- Hold the knife (4) at the knife back and carefully insert it in the holder from the side as shown with the cutting edge facing upward.

Adjusting the knife height

When adjusting the clearance angle, the cutting edge of the knife should be positioned in the center of rotation of the knife holder. The knife is correctly positioned in height when the cutting edge is at the level of the locating edge of the rear clamping jaws. The knife edge should be parallel with the locating edges.

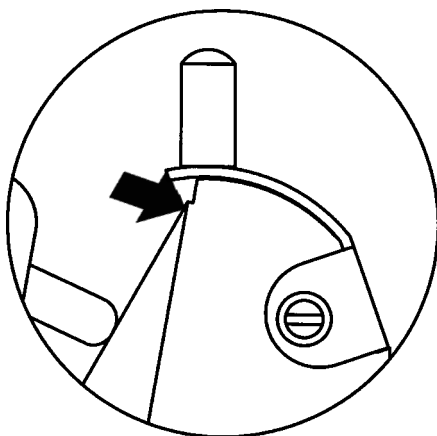

Fig. 48.2

- Turn the knurled wheels (6) in opposite directions to the rear to position the knife edge parallel and at the level of the locating edge (Fig. 48.2) of the rear clamping jaws.
- To clamp the knife (4), tighten the two clamping screws (2) uniformly by turning them clockwise.

Inserting blade rails

The blade rails are inserted in the knife holder and clamped like a knife.

12.3.2 Knife holder NZ

The knife holder NZ is appropriate for standard steel and tungsten carbide knives, profile c and d, up to 16 cm long. With its central clamping feature, the knife can be laterally repositioned and enables the use of the full length of the cutting edge. The knife can be repositioned in height. This enables the use even of frequently resharpened knives.

Mounting the knife support bar

- Push the knife guard (1) to the middle.
- Place the knife support bar (3) as shown on the height adjustment screws (not visible), ensuring that the flat top ends of the height adjustment screws are seated in the slots at both ends of the knife support bar.

Inserting the knife

- Turn the knurled wheels (6) on the right and left of the knife holder in opposite directions to the front to move the knife support bar via the height adjustment screws to the lowest position, to prevent damage to the cutting edge while inserting the knife.
- Unscrew the knife clamping screws (2) counterclockwise as far out as possible.
- Hold the knife (4) at the knife back and carefully insert it in the holder from the side as shown with the cutting edge facing upward.

Adjusting the knife height

Please refer to 12.3.1 Knife holder N (Fig. 48.2).

Lateral repositioning of the knife

- Push the knife guard (1) to the middle.
- Loosen the clamping screws (2) by turning them counterclockwise.
- Push the knife (4) to the left or right as required.
- To clamp the knife (4), always tighten the clamping screw (2) first which is located on the side to which the knife has been repositioned by turning it clockwise.

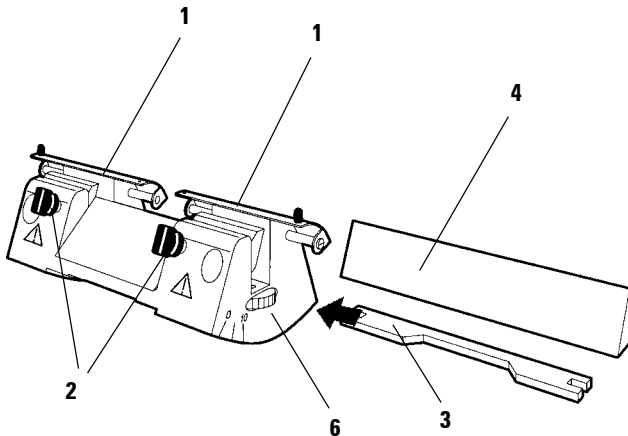

Fig. 49

12. Optional accessories

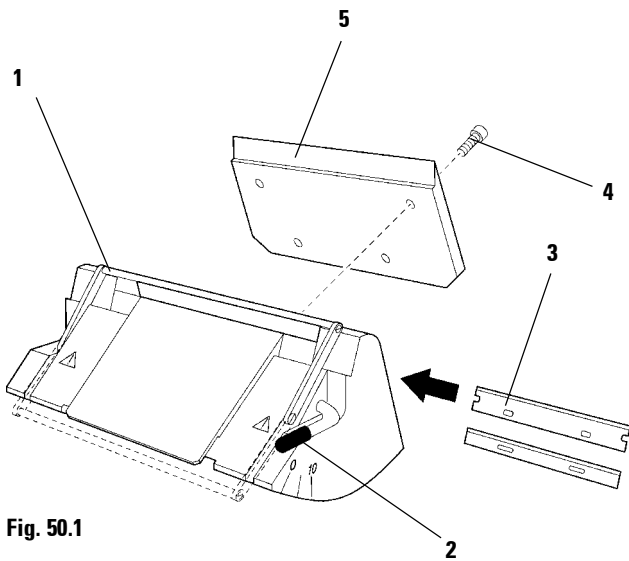

Fig. 50.1

12.3.3 Knife holder E

The knife holder E can be used with conventional disposable blades of all popular brands.

It is available in two versions, the difference being in the back pressure plate (5), one model being delivered with pressure plate for low profile blades, the other one with pressure plate for high profile blades.

Both types of pressure plates can also be ordered independently and fit both knife holder versions, i.e. if you wish to change from using low profile blades to using high profile blades and vice versa, you can do so with the same knife holder E by just ordering an additional pressure plate.

Inserting the blade

- Tilt the knife edge protection shackle (1) downwards.
- To insert the blade, pull the clamping lever (2) downwards.
- Insert the blade (3) from one side.
- To clamp the plate, rotate the clamping lever (2) upwards.

Exchanging the back pressure plate

- Loosen the four screws (4) on the back of the knife holder with a no. 4 Allen key.
- Remove the back pressure plate (5).
- Attach the new pressure plate with the 4 screws (4). Tighten the screws only slightly, so that as the next step you can adjust height and parallelism of the pressure plate.

Adjusting the back pressure plate

The back pressure plate (5) rests on two screws, which allow to adjust height and parallelism of the plate. The screws can be accessed through two bores on the underside of the knife holder and can be adjusted with a no. 2 Allen key.

- To remove the blade, pull the clamping lever (2) downwards.
- Carefully remove the blade (3) from the holder.
- Remove the clamping lever (2) by pulling sideways.
- With the two screws, adjust height and parallelism of the back pressure plate (5) in such a fashion, that the support surface for the disposable blade is at a level about 0.1 mm above the lateral jaws of the knife holder.
- Tighten screws (4).

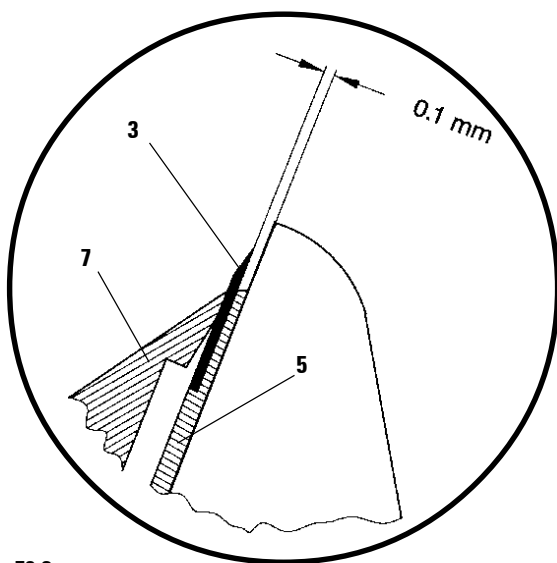

Fig. 50.2

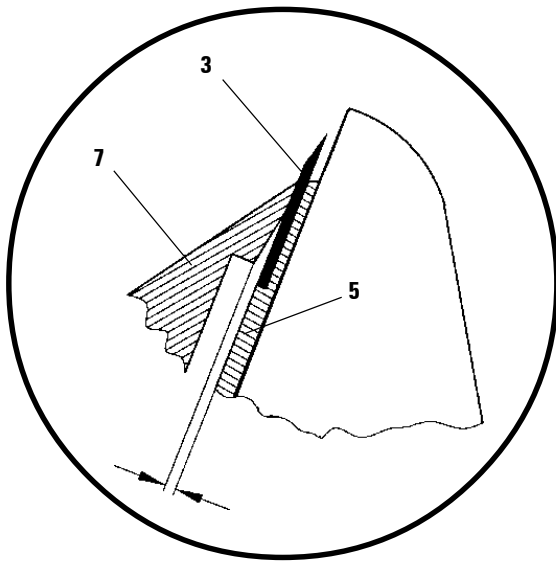

Fig. 51.1

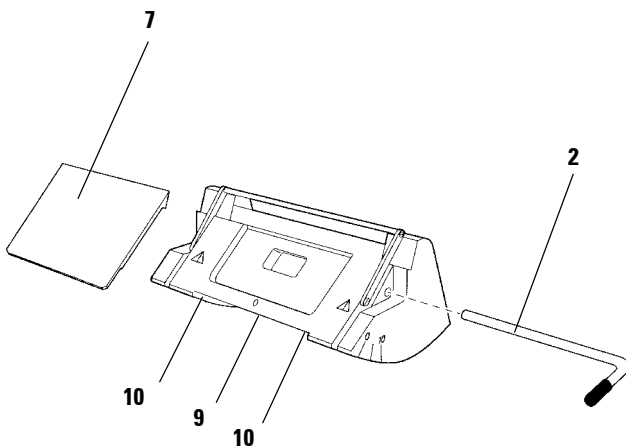

Fig. 51.2



Convenient for left-handers:
The clamping lever can also be inserted into the hole on the left side of the knife holder. (This, however, changes the clamping direction of the lever).
To unlock, push the lever upward - to clamp, tilt it downward.

Adjusting the front pressure plate

- Place the front pressure plate (7) in the correct position, insert the clamping lever (2) and tighten the pressure plate just slightly with the clamping lever..

The screws (10) on the underside of the knife holder are used to adjust the height of the pressure plate.

- Use the screws (10) to adjust the height of the pressure plate (7). The upper edges of both pressure plates (5) and (7) have to be at the same level and parallel to one another.

The clearance angle of the front pressure plate (7) is adjusted with screw (9), which is located in a bore on the underside of the knife holder and can be reached from the rear side of the knife holder.

- Insert a disposable blade, with the cutting edge facing downward to avoid injury, and clamp loosely with clamping lever (2).
- Adjust the front pressure plate (7) with screw (9) so that only the upper edge of the plate actually exerts any pressure on the blade. An opening must still be visible. Once the pressure plate is clamped tightly this gap will disappear.

Cleaning

For the purpose of a thorough cleaning the front pressure plate (7) can be removed.

- To remove the blade, tilt the clamping lever downward (2).
- Carefully remove the blade.
- Pull out the clamping lever (2) sideways.
- Remove the pressure plate (7).



Only use mild household cleaners / soap for cleaning. The varnish paint coat of the instrument is not resistant to acetone or xylene!

- Wipe with a damp (not wet!) cloth.
- Reattach the pressure plate (7). Reinsert the clamping lever (2) in the corresponding opening and tighten slightly.

12. Optional accessories

12.3.4 Knife holder E-TC

The knife holder E-TC is designed for the Leica TC-65 tungsten carbide blades.

Inserting the blade

- Push the knife guard (1) to the middle.
- To insert the blade, relocate the clamping lever (2) down.
- Carefully insert the tungsten carbide blade (3) from the side with the shining facet to the front.
- To clamp the blade, relocate the clamping lever (2) up.

Cleaning

The clamping plate (7) can be removed for cleaning.

- To remove the blade, relocate the clamping lever (2) down.
- Carefully remove the blade.
- Pull out the clamping lever (2).
- Remove the clamping plate (7).



Only use mild commercial detergents or soap solution for cleaning!
Do not use solvents that contain acetone and xylene!

- Clean all components with a damp not a wet cloth.
- Place the clamping plate (7) on the holder ensuring that the upper edge of the clamping plate and of the pressure plate (5) are parallel and at the same height.
- Insert the clamping lever (2) in the hole and relocate it up.

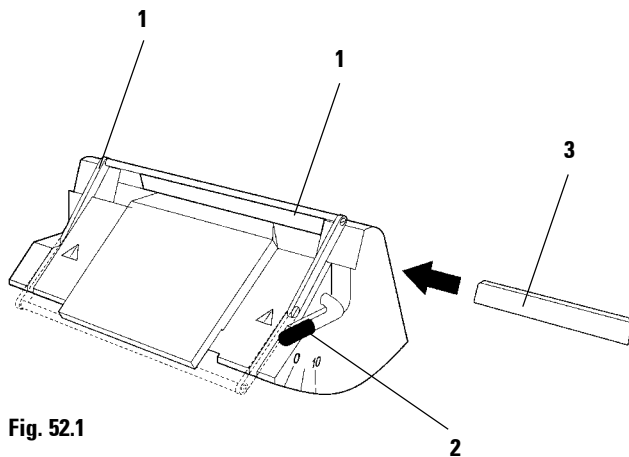

Fig. 52.1

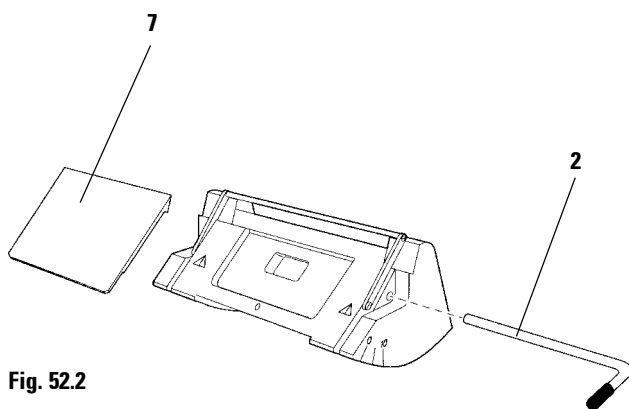

Fig. 52.2

12.4 Section waste tray

- Insert the section waste tray from the front underneath the microtome base plate.

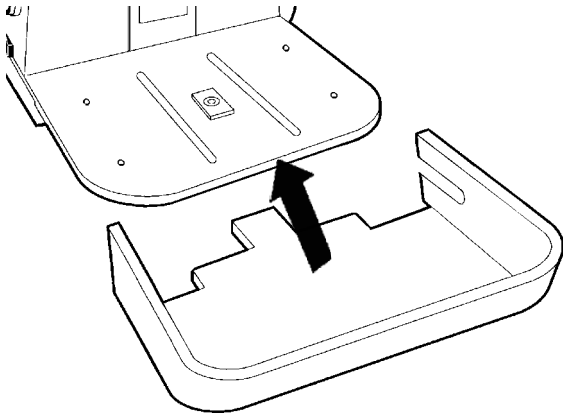

Fig. 53

12. Optional accessories



The combined carrier with magnifier and illumination can be mounted on all instruments that contain the appropriate fitting device inside the housing.

If the instrument is not equipped with such a fitting device, please contact your local Leica service department.

12.5 Combined carrier with magnifier and illumination

This carrier includes a fluorescent lamp. The inclination angle of the magnifier can be adjusted as appropriate. It is possible to slew the entire carrier to the side.



Protect the magnifier glass from exposure to direct sunlight! Exposure to sunlight may cause a burning glass effect. Risk of fire!

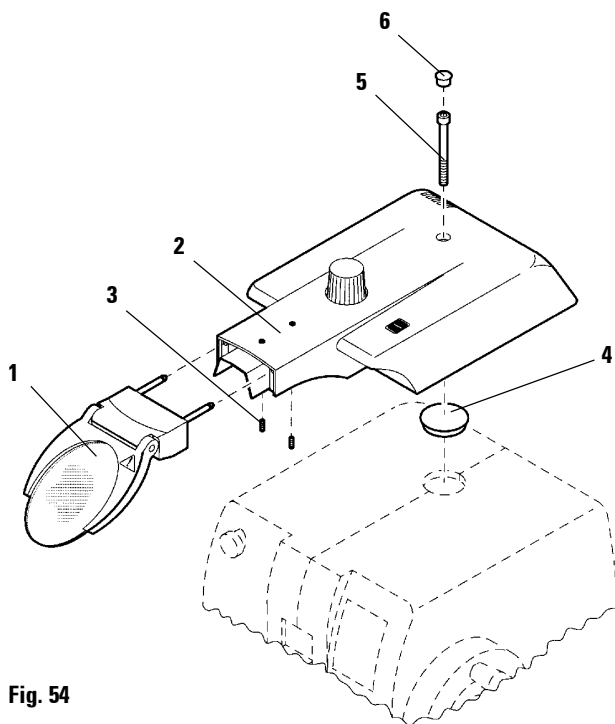

Fig. 54

Mounting the magnifier

- Introduce the pins (1) of the magnifier holder into the holes of the carrier (2) and push the holder entirely in.
- To fix the magnifier, insert the set screws (3) into the holes on the underside of the carrier and tighten with a screwdriver.

To disassemble, proceed in reverse order.

Mounting the carrier

- Turn the microtome off with the mains switch.
- Remove the cover cap (4).
- Introduce the screw (5) into the hole of the carrier (2).
- Place the carrier (2) with the screw on the microtome housing so that the screw is located in the hole of the fitting device inside the housing.
- Tighten the screw (5) with an Allen key size 6.
- Close the hole with the cover cap (6).

To disassemble, proceed in reverse order.



Do not operate the magnifier & illumination carrier at a power rating other than specified on the nameplate!

Connecting the mains cable and turning on

- Connect the mains cable (7) to the socket at the rear of the carrier.
- Place the mains plug into the mains power outlet socket.
- Turn on with the mains switch (8).

Carrier adjustments

- The carrier (2) can be repositioned back and forth on the microtome housing.
- It also may be swung to the side if required. To do so, slightly lift the carrier at front and move as desired.
- The carrier may be adjusted in height by means of the knob (9).
- The inclination angle of magnifier (1) can be adjusted as required.

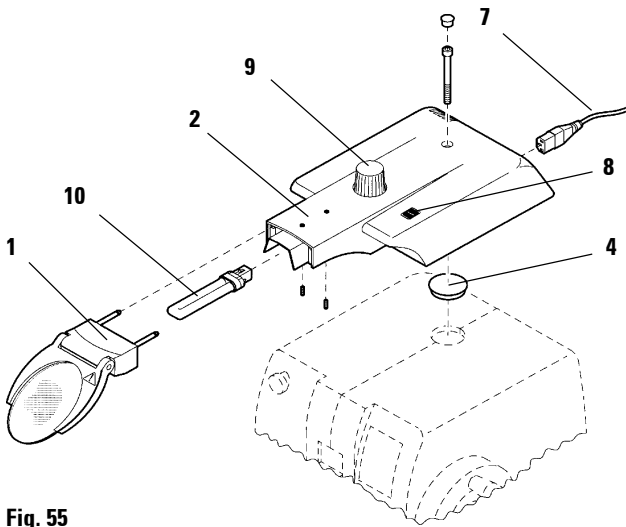

Fig. 55



Prior to replacing the lamp, turn the illumination off with the mains switch (8) and disconnect the carrier from the mains power supply!

- Fold the magnifier (1) up.
- Pull the lamp (10) out of the holder.



**Use lamp of the same specification only!
Lamp type: Osram DULUX 7 W.**

- Lightly push the new lamp into the holder until it locks in place.
- Reconnect the carrier to the mains power supply.
- Turn on with the mains switch.

12. Optional accessories

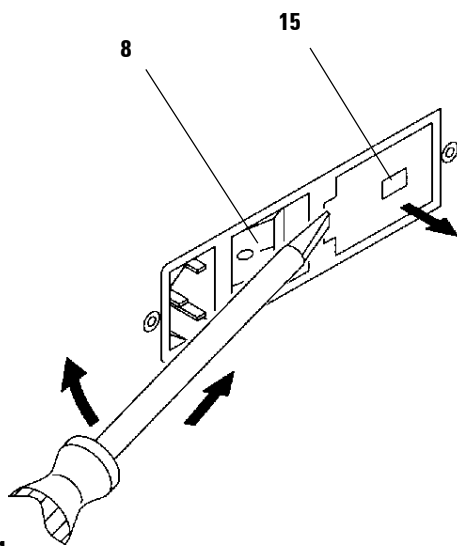

Fig. 56.1

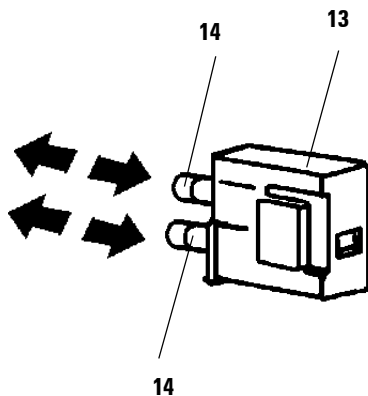

Fig. 56.2

Fuse replacement



Prior to replacing the fuses, turn the illumination off with the mains switch (8) and disconnect the carrier from the mains power supply!

The fuses are located in the voltage selector housing (3).

- Place the tip of a small screw driver into the small recess of the cover and push carefully to remove.
- Pull out the voltage selector housing (13).
- Remove the fuses (14).



**Use fuses of the same specification only!
For correct fuse type, see label on the carrier.**

- Mount new fuses of the same technical specification.

The actual voltage setting can be seen in the small window (15) of the voltage selector housing.

- Insert the voltage selector housing with the fuses into the instrument, lightly push until it locks in place.
- Check if the correct voltage is indicated in window (15).
- Reconnect the mains plug.
- Turn on with the mains switch.



The microscope carrier with fiber optical light guide can be mounted on all instruments that contain the appropriate fitting device inside the housing.
If the instrument is not equipped with such a fitting device, please contact you local Leica service department.

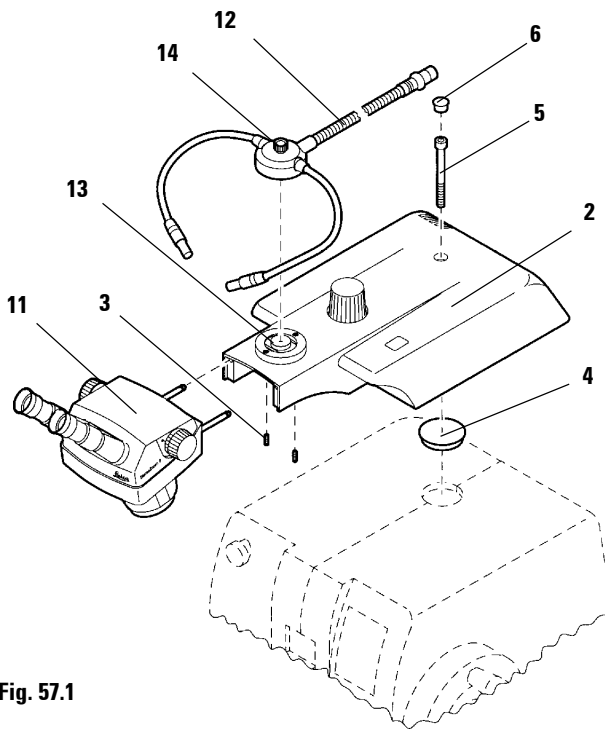

Fig. 57.1

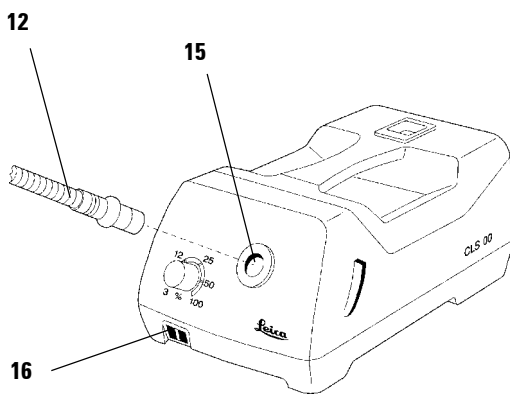

Fig. 57.2

12.6 Microscope carrier

The microscope carrier is supplied with a two-armed fiber-optical light guide for connection to the cold light sources of the Leica CLS series. The carrier can be slewn to the side if required. To focus the microscope, the carrier can be adjusted in height.

Mounting the microscope

- Introduce the pins of the microscope adapter (11) into the holes of the carrier (2) and push the adapter in entirely.
- To fix the magnifier, insert the set screws (3) into the holes on the underside of the carrier and tighten with a screwdriver.

To disassemble, proceed in reverse order.

Mounting the microscope carrier

- Turn the microtome off with the mains switch.
- Remove the cover cap (4).
- Introduce the screw (5) into the hole of the carrier (2).
- Place the carrier (2) with the screw on the microtome housing so that the screw is located in the hole of the fitting device inside the housing.
- Tighten the screw (5) with an Allen key size 6.
- Close the hole with the cover cap (6).

To disassemble, proceed in reverse order

Mounting the fiber-optical light guide

- Place the light guide (12) onto the receptacle (13) of the carrier as shown and fix by tightening the screw (14).

Connecting the coldlight source

- Push the light guide (12) into the socket (15) of the coldlight source.



For details about connection and operation of the coldlight source, please refer to the instruction of the cold light source.

12. Optional accessories

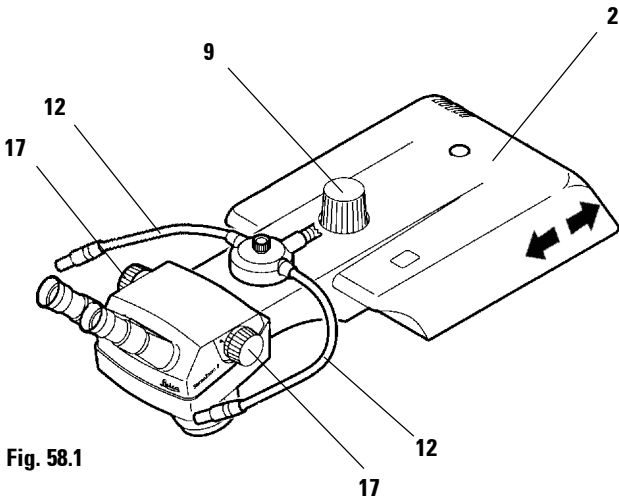

Fig. 58.1

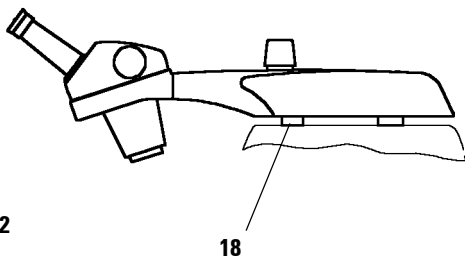

Fig. 58.2

Carrier adjustments

- The carrier (2) can be repositioned back and forth on the microtome housing.
- It also may be slewn to the side if required. To do so, slightly lift the carrier at front and move as desired.
- To focus the microscope, the carrier may be adjusted in height by means of the knob (9).
- The flexible arms of the light guide (12) can be placed in the optimum position. One spot can be directed on the sample, whilst the other may be directed on the knife.

Sectioning with a microtome will inevitably cause vibrations, which might be disturbing when using the microscope at great magnification factors.

An adjustable plastic device (18) is located on the underside of the carrier. To eliminate such disturbances, readjust the plastic device.

- Slew the carrier (2) to the side.
- Screw the plastic device (18) further in our out as required.
- Slew the carrier (2) back.
- Adjust the microscope zoom with the knurled knobs (17).



A magnifier (optional accessory) may be used as an alternative to the microscope. Please refer to the combined carrier with magnifier and illumination for mounting instructions.

12.7 Hand rest



The hand rest is supplied with two long clamping levers for the knife holder base. The trimming lever extension included can only be used on the RM 2135.

12.7.1 Mounting the hand rest

Depending on the type of universal knife holder base you are using, the short clamping lever(s) will have to be removed before mounting the hand rest.

- To release, turn the clamping lever (1) counterclockwise.
- To release, turn the clamping lever (2) (only on the knife holder base with lateral displacement function) clockwise.
- Pull the lever(s) out of the knife holder base.



The universal knife holder without lateral displacement function has a hole on the left side that is covered with a cap. The cap can be removed with a screwdriver. The hole is provided to accommodate a second clamping lever for stabilizing the hand rest.

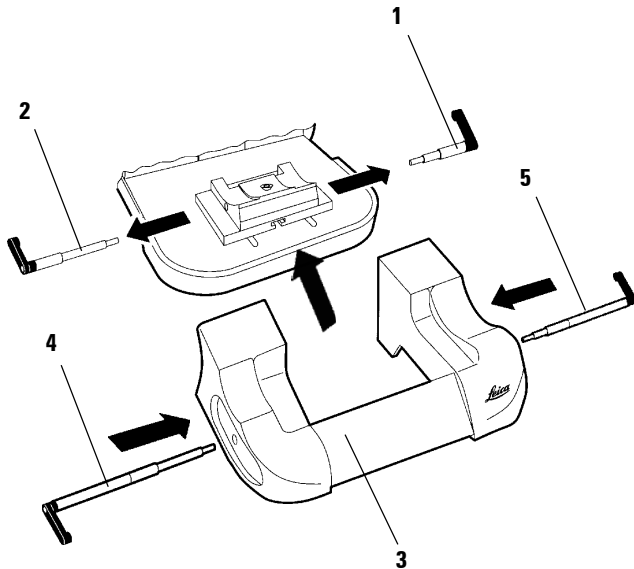

Fig. 59

- Place the hand rest (3) on the microtome base plate.
- Introduce the longer clamping lever (4) on the left and the shorter clamping lever (5) on the right through the holes of the hand rest in the holes of the knife holder base and turn them to the required direction to clamp.

12. Optional accessories

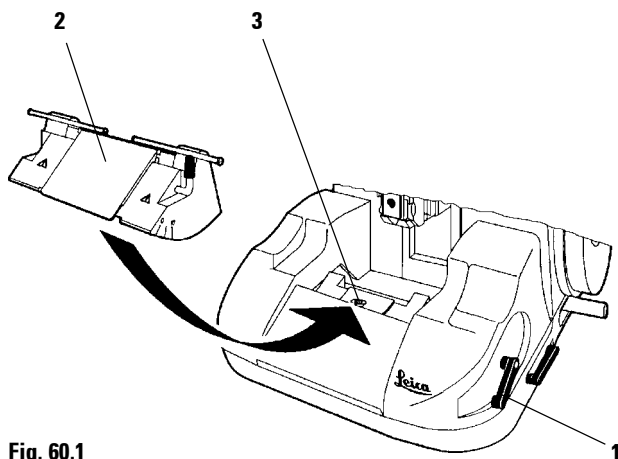

Fig. 60.1

12.7.2 Installing the knife holder

- Turn the clamping lever (1) counterclockwise to release the clamping.
- Slide the knife holder (2) onto the T-piece (3) of the knife holder base.
- To lock, turn the clamping lever (1) clockwise.

12.7.3 Adjusting the clearance angle

The scale for the clearance angle adjustment (0°, 5° and 10°) is located on the right side of the knife holder. A reference point is provided on the hand rest.

- To release, turn the clamping lever (3) counterclockwise.
- To adjust the clearance angle, slide the knife holder on the base until the reference point on the hand rest or line is located next to the scale line for the required adjustment.
- Hold the knife holder in this position and fix the adjustment by turning the lever (3) clockwise.

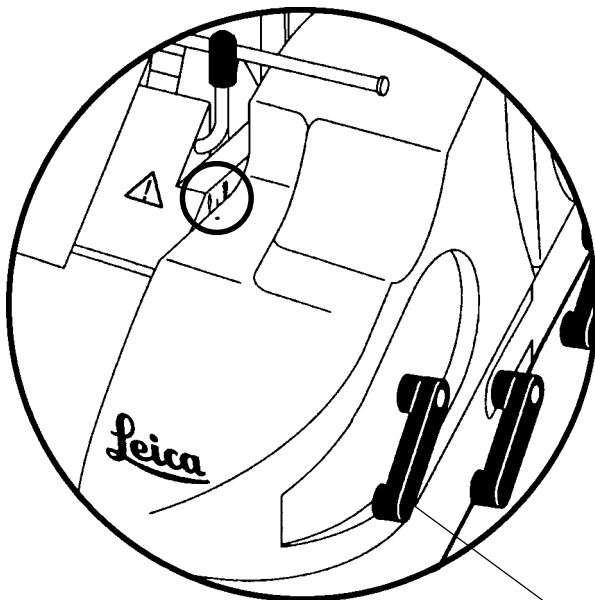

Fig. 60.2

12.7.4 Repositioning the knife holder base



The hand rest and knife holder do not need to be removed as they are repositioned with the knife holder base.

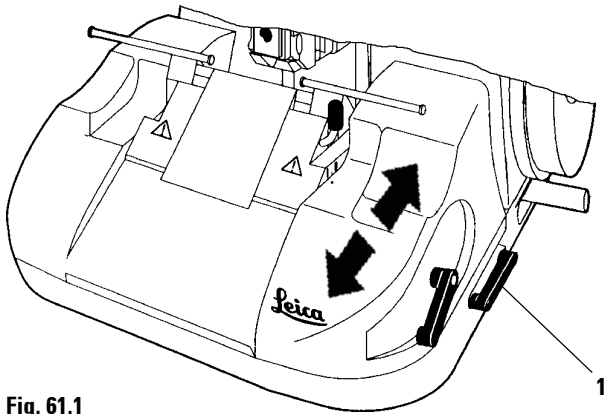

Fig. 61.1

North/South

North/South displacement enables to approach the knife holder to the sample as close as possible.

- To release, turn the clamping lever (1) on the right side of the microtome base plate counterclockwise.
- Reposition the knife holder base together with the knife holder and the hand rest forward or backward as appropriate.
- To clamp, turn the clamping lever (1) clockwise.

East/West

(only knife holder base with lateral displacement function)

The lateral displacement feature of the knife holder base enables the use of the entire length of the blade or knife eliminating the need for readjusting the knife holder.

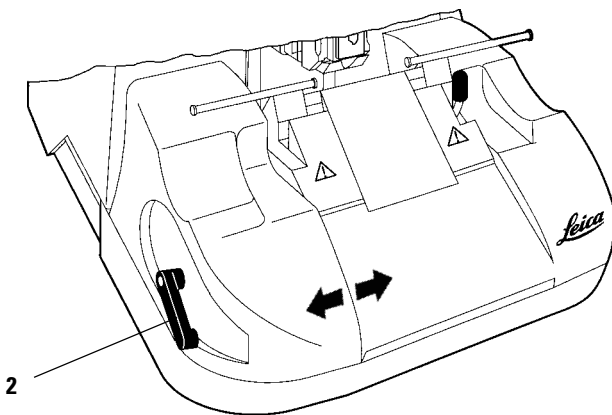

Fig. 61.2

- To release, turn the clamping lever (2) on the left of the hand rest clockwise.
- Reposition the knife holder base together with the hand rest and knife holder sideways as appropriate.
- To clamp, turn the clamping lever (2) counterclockwise.

12. Optional accessories

12.8 Exchanging the fixture for specimen clamps



Depending on your individual order, the instrument is delivered with either the orienting or the non-orienting fixture for specimen clamps. Both fixtures are interchangeable.

12.8.1 Disassembling the orienting fixture for specimen clamps (Fig. 62.1)

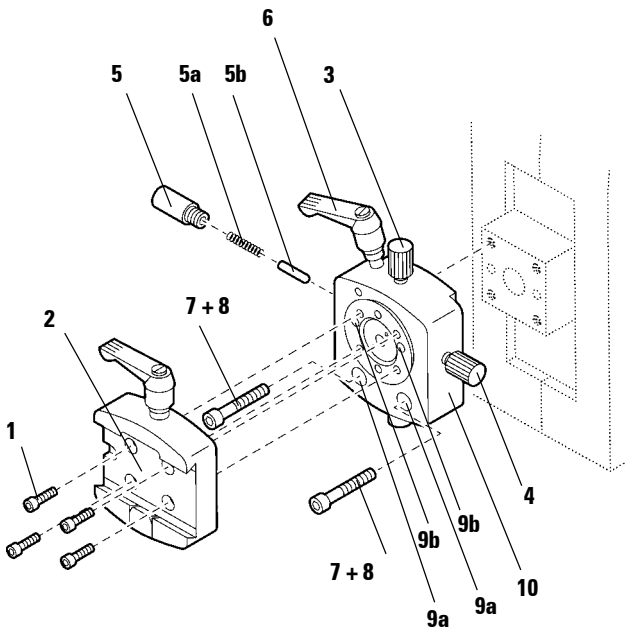

Fig. 62.1

- Activate the handwheel locking system.
- Remove the knife holder.
- Remove the specimen clamp from the fixture for specimen clamps.
- Detach the four screws (1) with a no. 3 Allen key and remove the dovetail adapter (2).
- Unscrew the adjusting screws (3) and (4) completely.
- Completely unscrew pressure piece (5) with a slotted screw driver and remove it together with spring (5a) and pin (5b).
- Release eccentric bolt (6) rotating counterclockwise.
- Evenly unscrew both screws (7) and (8), accessible through the bores holes (9), and remove the orienting fixture for specimen clamps (10).

To reassemble, proceed in reverse order.

12.8.2 Assembling the non-orienting fixture for specimen clamps (Fig. 62.2)

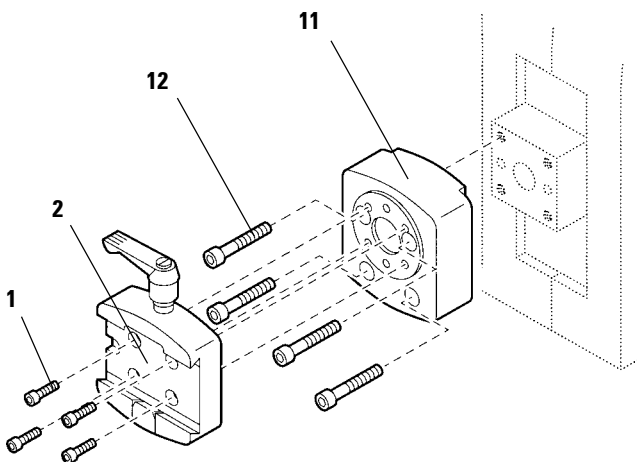

Fig. 62.2

- Attach the non-orienting fixture (11) to the specimen cylinder as shown in Fig. 61.2 and secure with the four corresponding screws (12) (use no. 4 Allen key).
- Attach the dovetail adapter (2) and tighten the four screws (1) with a no. 3 Allen key.

To disassemble, proceed in reverse order.

13.1 Ordering information

Knife holder system

Universal knife holder base without lateral displacement	
with one short clamping lever for use with the right and left side arm rests	0500 30147
with two long clamping levers for use with the hand rest	0502 29585
Universal knife holder base with lateral displacement	
with two short clamping lever for use with the right and left side arm rests	0500 29703
with two long clamping levers for use with the hand rest	0502 29954
Knife holder N	0502 29955
Knife holder NZ	0502 29956
Knife holder E for low profile disposable blades	0502 29957
Pressure plate for high profile blades	0502 29553
Knife holder E for high profile disposable blades	0502 29982
Pressure plate for low profile blades	0502 29551
Knife holder E-TC	0502 29958
Knife holder GD for glass and diamond knives	0502 29959
Trimming insert for knife holder GD, for clamping EM specimen holders or segment arc	0402 20369
Insert for Ralph knives for knife holder GD with clamping frame for 25 mm knives	0402 09996
Insert for Ralph knives for knife holder GD with clamping frame for 38 mm knives	0402 09997

Specimen clamping systems

Specimen clamping system, non-orienting	0502 29963
Specimen clamping system, orienting	0502 29962
Standard specimen clamp with adapter (50 x 55 mm)	0502 29964
Standard specimen clamp with adapter (40 x 40 mm)	0502 29980
Universal cassette clamp with adapter	0502 29965
Vee insert for round specimens	0402 09299
Foil clamp, type I	0402 09307
Foil clamp, type II	0402 26922
Holder for round specimens with adapter and three inserts	0502 29979
Holder for round specimens with adapter, w/o inserts	0502 29522
Insert for holder for round specimens, \varnothing 6 mm	0356 08322
Insert for holder for round specimens, \varnothing 15 mm	0356 09200
Insert for holder for round specimens, \varnothing 25 mm	0356 08320
Holder, non-orienting, for EM specimen holder	0502 29968
Segment arc, with adapter, for EM specimen holder	0502 29969
Universal specimen holder (EM)	0356 10868
Flat specimen holder (EM)	0355 10405
Special wrench for EM specimen holders	0356 10869

13. Appendix

Optional accessories

Foot switch with protective guard, including foot switch adapter	0502 29977
Foot switch adapter	0502 29413
Section waste tray	0500 29807
Hand rest, including two long clamping levers and long trimming lever	0500 30143
Backlighting for one-piece universal knife holder base and for knife holder GD	0502 29970
Combined carrier 'magnifier & illumination' - 100 V, 50/60 Hz	0502 29364
- 120 V, 50/60 Hz	0502 29971
- 230 V, 50/60 Hz	0502 29972
- 240 V, 50/60 Hz	0502 29365
Microscope carrier including stereo-zoom microscope, eye pieces, microscope adapter and fiber optical light guide w/o cold light source	0502 29366
Leica CLS 100 cold light source - 100 V, 50/60 Hz	0502 29364
- 120 V, 50/60 Hz	0502 29971
- 230 V, 50/60 Hz	0502 29972
- 240 V, 50/60 Hz	0502 29365
Plug-in magnifier for use with microscope carrier	0502 29973

Standard accessories for repeat orders

Arm rest, right	0500 29608
Arm rest, left	0500 29609
Maintenance kit	0502 29360
Cover cap	0430 18995
Dust cover	0212 30350
Instruction manual V 3.1 – 02/2001 (German, English, French, Spanish)	0700 37108

Product changes

Due to a policy of continuous improvement of our products, Leica Microsystems Nussloch GmbH reserves the right to change specifications without notice.

Warranty

Leica Microsystems Nussloch GmbH guarantees that the delivered product has been subjected to a comprehensive quality control procedure based on our strict in-house testing standards in order to ensure that the product complies with its technical specification. The warranty conditions depend on the contents of the individual contract concluded, supplemented by the warranty conditions of your local Leica sales agency. Any repairs and/or exchange of parts of the product must be carried out by authorized Leica technical service engineers. Otherwise, any warranty becomes invalid and warranty claims can no longer be made. The local Leica representative or the manufacturer in Nussloch must be consulted prior to any handling of or changes to the instrument beyond the scope of this instruction manual as well as prior to any modifications or any use of the instrument in combination with non-Leica components not expressly authorized by Leica. Spare parts and accessories not supplied by Leica can under no circumstances be considered as inspected and/or approved by Leica. Therefore, installation or use of any such parts may impair the technical design features and thus properties of the instrument.



Leica assumes no liability whatsoever for any damage caused by the use of non-original spare parts or non-original accessories.

The warranty is only valid and warranty claims can only be made as long as the instrument has been operated according to its designated use and according to the instructions given in this manual.

Improper use of the product and/or faulty operation invalidate the warranty and any claims based thereon, and likewise Leica will not assume liability for any consequential damage.

Disposal

The instrument or parts of the instrument must be disposed of in compliance with the local laws.

The Leica RM 2145 contains a great number of recyclable components. For more information about our recycling program, please contact your local Leica Sales Representative or Dealer, or Leica Microsystems Nussloch GmbH in Germany.

We will be glad to provide you with details on the recycling concept for our microtomes meeting today's environmental requirements.

Technical service information

If you require technical service or replacement parts under warranty, please contact your Leica Sales Representative or Dealer from whom the instrument was purchased.

Be sure to state the model type, serial number and date of delivery. Leica Microsystems Nussloch GmbH (Germany) cannot accept goods returned without official authorization.

If an instrument or any part of it is to be returned to Leica, please note the following:

- a. If the instrument or any part of it has been exposed to or been in contact with potentially pathogenic or radioactive materials, it is essential to decontaminate the instrument or part. Decontamination must explicitly be confirmed by the customer. Our service engineers have to enquire about this.
- b. Ensure that there is no radioactivity or hazardous bacteria present and advise Leica of any decontamination procedure that may have been carried out.

Should the instrument or any part of it be received in a condition that Leica considers to be a potential biological hazard, the instrument or part will be returned unrepaired at the expense of the customer.

When requesting a service call, please provide the following information:

- a. Model type and serial number of the instrument;
- b. Location of the instrument and the person to contact;
- c. The reason for the service call.

