

OPERATOR MANUAL

Rankin Basics Embedding Station & Cryo Plate

EMB5

Embedding Console Model: EMB51

Cryo Console Model: EMB52



Attention: Before using the instrument, please read this Instruction carefully, and keep the Instruction for further reference.

Please refer to the nameplate on the back of the instrument for the serial number and manufacturing date of the instrument.

Contents

1. INTRODUCTION	2
2. SAFETY REGULATIONS	2
3. EMBEDDING UNIT.....	4
Features	5
Specifications	5
Operation.....	6
Basic procedures	6
Temperature/Timer/Clock Setting	8
CRYO key.....	10
4. CRYO PLATE	11
Features.....	12
Specifications.....	12
Operation.....	12
5. PRECAUTIONS	13
6. MAINTENANCE AND STORAGE.....	13
7. TROUBLESHOOTING	14
8. LIMITED WARRANTY	15

1. INTRODUCTION

This tissue embedding center consists of an embedding unit and a cryo plate, which can be used either separately or as a set. It is designed for embedding human/animal/plant tissues with paraffin and cooling the tissue blocks after embedding. The advanced controlling-microprocessor and the new PTC calorific material are applied to precisely control the individual temperature of five parts with multi-level over-heat protection. Users can set up power on/off timers to minimize the waiting time for paraffin melting. The cooling element adopts a new-type frequency converting compressor to provide a precisely controlled, adjustable cryo temperature.

With its novel design, this instrument set has a high precision, stable performance, and easy operation. It is recommended for use in hospitals, medical schools, scientific research institutes, and food quarantine and inspection organizations.

2. SAFETY REGULATIONS

Package handling

- Please inspect the package and contact the shipper if the package has serious damage.
- Please place the instrument on a stable surface after taking it out from the wooden box.
- Don't place the instrument in an environment near explosive or flammable material.
- If the instrument may need to be transported again, we suggest using the original packaging materials.

Safe installation

 The instrument should be installed in a place near the grounding outlet to ensure that the power supply line can be safely connected.

 Please ensure the grounding wire of the 3-line power is securely connected before starting the instrument, which must comply with the GB9706.1 standard. Please ensure the socket is stable before connecting it and turning on the power switch.

- An independent power source should be supplied for the instrument.
- The instrument shall be operated in a place away from any electromagnetic interferences.
- The instrument should be placed steadily, averting vibration.
- When the power is on and the embedding unit is started,  indicates heating has started, do not use your hands to touch any heating parts of instrument (such as paraffin tank, left and right cassette storage chambers, paraffin dispenser, working plate, and forceps holder).

Attention: *Don't keep heating elements on for an excessive period of time when the instrument is not in use. Don't operate the instrument under a fan, which would affect the cryo performance.*

⚠ Please ensure the power supply is disconnected before removing any electrical components, such as fuses and lighting elements.

- Please ensure no excessive amount of liquid wax flows onto the surface of the instrument, which might leak into the inside and damage the instrument. The filter at the bottom of the paraffin tank should be installed properly and kept clean to allow a smooth wax flow. The working plate and surface should be cleaned daily.

Working Environment

- Temperature: 5°C~40°C
- Humidity: < 80%
- Atmospheric pressure: 860hpa~1060hpa

Transportation

- The instrument should only be transferred in an upright position.
- Please ensure the power supply is disconnected before cleaning the instrument. Don't use any solvents containing ketone or benzene. Don't allow any solvent to flow into the inside of the instrument.
- Please comply with the safety regulations of the manufacturer and related laboratory rules when using solvents.

3. EMBEDDING UNIT

The embedding unit consists of five heating parts and one cryo part (see picture 1).

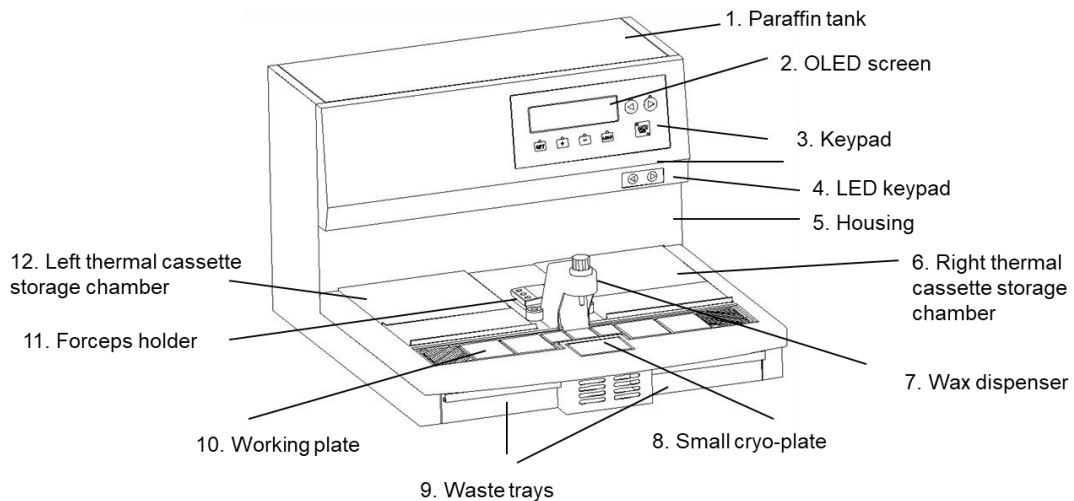

Front pad

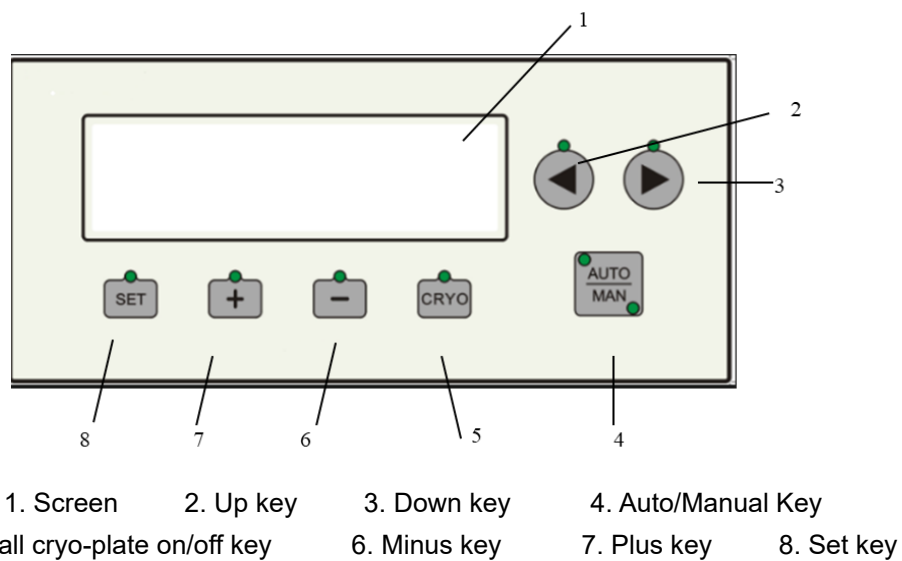

Back Panel

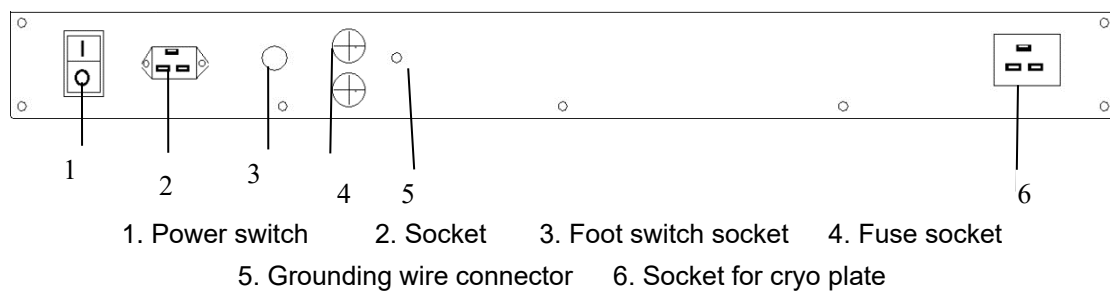

3.1 Features

- On/off timer: The timer setting as 00 Hour 00 minute for a specific day indicates the instrument will not turn on automatically on that day.
- Crisp and stable OLED screen: It will enter into screen protection mode after 15 minutes without operating the keypad in the automatic working condition.
- Histo-trimmers on the two ends of the heating plate are convenient for trimming cassettes.
- Flexible magnifier.
- Two modes of operation: Automatic and manual.
- Keys with light indicator.
- Low voltage and adjustable LED illuminating system with flexible mount.
- Two module configuration options (left to right or right to left).
- Volume of paraffin tank: ≥ 6 L.

3.2 Specifications

- Electric security: class I
- Temperature range: ambient to 85°C
- Temperature range of cryo-plate: $\leq -5^{\circ}\text{C}$
- Temperature tolerance: $\pm 1^{\circ}\text{C}$
- On/off timer: Any minute, any hour, and any weekdays
- Paraffin tank: 494mm L \times 131mm W \times 92mm H
- Left and right thermal chamber: each 240mm L \times 160mm W \times 55 mm H
- Working plate: 540mm L \times 93mm W
- Voltage: AC110V 60HZ
- Power: 1000VA
- Overall dimensions: 675mm L \times 575mm W \times 395mm H
- Weight: 86 Lbs.

3.3 Operation



Please use only the power cord supplied with the instrument and ensure that the grounding socket is connected.





Please ensure the power switch is in the “O” position (the off position) before connecting the instrument to the main power supply.

The “I” position of the power switch indicates that the power is turned on and the “O” position is power off. Once the switch is turned on, the indicator light of switch will be on.

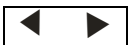

Please ensure that the cord is connected to the instrument first before connecting another end to the main power supply.

Basic procedures

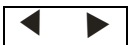
1. The first step is to fill the paraffin tank. Please do not fill too much and risk wax overflowing.
2.   on the keypad are for the LED light. Press  key to increase the brightness and press  key to decrease the brightness of LED light.
3. Before using the embedding unit, please set the temperatures for the six working zones.

Note: The temperatures for six working zones are preset as: Left thermal chamber: 55 °C, Paraffin dispenser: 70 °C, Paraffin tank: 65 °C, working table: 55 °C, right thermal chamber: 65 °C, small cryo-plate: -10 °C.



After the temperature presetting is confirmed, the user can turn on the heating and run the instrument.



indicates heating;



indicates stopping heating.

Note: If the instrument is turned on in pre-setting ON time, it will automatically start to run. Before the actual temperature reaches the setting temperature, the heating symbol  will automatically appear, and it will change to  when the temperature reaches the setting temperature.

The screen enters the protection and power-saving mode after 15 minutes without touching the keypad. The screen can be lighted by pressing any key except the CRYO key.

Press the AUTO/MAN key, the instrument will switch between the auto and manual modes.





Note: If the turn ON time is not pre-set, the instrument will enter the waiting interface as below:

【AUTO MODE】	Running.....	FRI	18:40
PARAFFIN: 62°C		RIGHT : 60°C	
HOT PLATE : 60°C		LEFT : 55°C	
DISPENSER : 65°C		CRYO : ●	

To start the instrument, please press AUTO/MAN key to enter the manual interface.

【MAN MODE】	off work	FRI	18:40
PARAFFIN: 62°C		RIGHT : 60°C	
HOT PLATE : 60°C		LEFT : 55°C	
DISPENSER : 65°C		CRYO : ●	

Press  to enter the running mode and press  to return to the waiting mode

【AUTO MODE】	Running.....	FRI	18:40
PARAFFIN: 62°C		RIGHT : 60°C	
HOT PLATE : 60°C		LEFT : 55°C	
DISPENSER : 65°C		CRYO : ❄	

TEMPERATURE/TIMER/CLOCK setting

Press SET key to enter the setup mode. Press ◀ or ▶ key to choose the setting item.

【SETUP MODE】 SELECT(1—3)
1. TEMPERATURE
2. TIMER
3. CLOCK

Temperature setting:

Select “1. TEMPERATURE” and press SET key to enter the temperature setting interface. Press ◀ or ▶ to choose the working zone, and press + or – to increase or decrease the temperature. After finishing setting, press AUTO/MAN key to return to the running interface.

【SET TEMPERATURES】 SELECT(1—6)	
1. PARAFFIN: 62°C	2. RIGHT : 60°C
3. HOT PLATE : 60°C	4. LEFT : 55°C
5. DISPENSER : 65°C	6. CRYO : ❄

1. PARAFFIN (paraffin tank); 2. RIGHT (right thermal chamber); 3. HOT PLATE (working plate); 4. LEFT (left thermal chamber); 5. DISPENSER (paraffin dispenser); 6. CRYO (small cryo-plate).

Timer setting:

Select “2. TIMER” and press SET key to enter the timer setting interface.

Press ◀. ▶ to set turn on and turn off time from Monday to Sunday. Press + or – to increase and decrease the time figure.

【 SET TIME 】	SELECT(1—7)
1. MON: 06:10 [ON]	16:30 [OFF]
2. TUE : 08:10 [ON]	16:30 [OFF]
3. WED : 09:10 [ON]	16:30 [OFF]

Press ► to choose timer setting for Thursday, press ◀ to return to timer setting for Monday. After finishing the setting, press **AUTO/MAN** key to return to automatic running interface.

4. THU: 06:10 [ON]	16:30 [OFF]
5. FRI: 06:10 [ON]	16:30 [OFF]
6. SAT : 07:10 [ON]	16:30 [OFF]
7. SUN : 06:10 [ON]	16:30 [OFF]

Example:

To turn on at 7:30 and turn off at 12:50 on Tuesday, the setup steps are as below:

Turn on the power and press **AUTO/MAN** key to enter the waiting mode, press **SET** key then press ► to choose “2. TIMER”, press ► to choose Tuesday and press + or – to set 07:30 [ON] 12:50 [OFF] .

Note: Set both the On and Off time as 00:00 on the day when there is no need to operate the instrument.

Clock setting

Select “3. CLOCK” and press **SET** key to enter the current time setting interface.





Press ◀ or ► to choose minute, hour, week, then press + or – to increase or decrease the time figures. Press **AUTO/MAN** key to return to the running interface.

【 SET CLOCK 】	SELECT(1—3)
1. MINUTE :	05
2. HOUR:	09
3. WEEK:	FRI

All the temperature/time settings will be stored and automatically applied after pressing the AUTO/MAN key when the embedding unit is restarted.

CRYO key

If the CRYO key is pressed under the AUTO mode, the cryo plate connected to the embedding unit will be turned on/off. ❄ indicates the cryo plate is running and the absence of ❄ indicates the cryo plate is not running.

【AUTO MODE】	Running.....	FRI	18:40
PARAFFIN: 62°C		RIGJHT : 60°C	
HOT PLATE : 60°C		LEFT : 55°C	
DISPENSER : 65°C		CRYO :	❄

4. CRYO PLATE

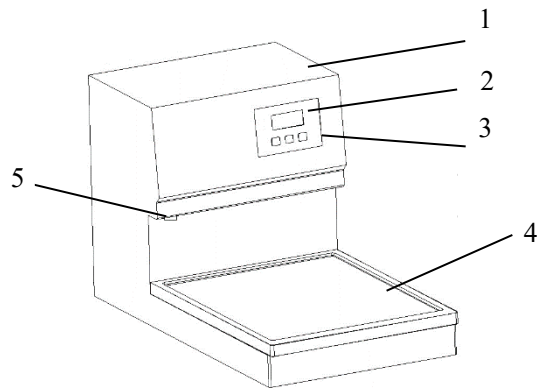

1. Housing 2. Screen 3. Keypad 4. Working area 5. Switch

Front panel

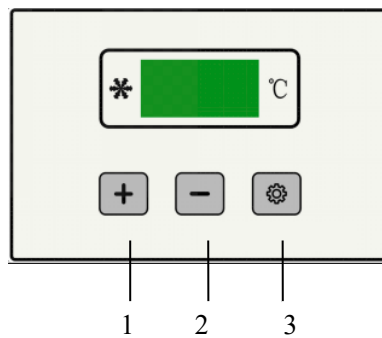

1. Increase 2. Decrease 3. Setting

Back panel

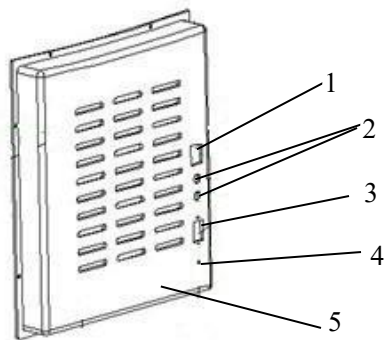

1. Power switch 2. Fuse socket 3. Power socket
4. Grounding wire connector 5. Back cover

4.1 Features

- Temperature range is from +5°C to -28°C and the actual plate temperature will be affected by ambient conditions.
- Stable green-background digital screen.
- The temperature measurement module with high precision and good performance is made by US DALLAS.

4.2 Specifications

Digital screen indicates actual temperature.

- Electric security: class I
- Temperature range: 5°C to -28°C
- Working area: 315×380 mm
- Voltage: AC110V 60HZ
- Power: 300VA
- Fuse: F1A/AC250V
- Overall Dimension: 710mm L×350mm W×390 mm H
- Weight: ~ 35 Lbs.

4.3 Operation

1. Connect the cryo plate to the power and turn on power switch.

If the power switch shows green light, that indicates the cryo plate has power and the interface is as below (-10°C is preset by the manufacturer):

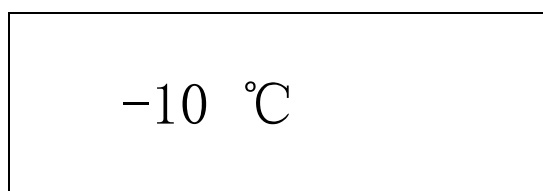

2. Press the **SET** key to enter the setting mode and then press + or - to adjust the temperature. Then press SET key to enter the running mode.

5. PRECAUTIONS

- NEVER use a non-grounded power source for this instrument.
- Before the paraffin is melted completely and the dispenser temperature reaches the preset temperature, do NOT use the hand or foot switch to turn on the wax dispenser; otherwise, the dispenser might be blocked.
- The instrument has an over-heat protection system, which will shut down the power automatically when the temperature of the heating elements exceeds 100°C.
- In order to prolong the lifetime of the compressor in the cryo plate, please avoid running the compressor continuously for more than 4 hours.
- Please do NOT use any hard objects to touch the LCD screen.
- Please do NOT touch any heated area with your hands.
- Please do NOT place any liquid near the instrument while it is running.
- Please use ONLY the fuse provided with the instrument by the manufacturer and do NOT change the fuse without turning off the main switch and disconnecting the power supply.
- Please do NOT use xylene and acetone and other organic solvent to clean the surface of the equipment.

6. MAINTENANCE AND STORAGE

- Environmental conditions for operation and storage of the instrument: Temperature -10°C~+55°C; Humidity < 80%; Atmospheric pressure: 860 hpa~1060 hpa
- The instrument should be cleaned daily to remove wax on the surface and chambers after use. Use only cleanser for home use to gently wipe the surface of the instrument.
- Paraffin repellent spray is recommended to ease the wax residual removal.
- The power supply must be disconnected before cleaning the instrument.
- Please turn off the main switch, disconnect the power supply, and cover the instrument with a dustproof cover if the instrument is not in use.

7. TROUBLESHOOTING

Defect	Possible cause	Solution
Embedding Unit		
No response after the power switch is turned on	Power line is not connected well	Reconnect the power line, turn the power on again, and the indicator light is on
	Blown or defective fuse	Check the fuse and replace it if needed.
Light isn't on	Blown fuse	Check the fuse and replace it if needed.
No heating	Blown fuse	Change the fuse if needed.
	Defective heating element	Ask for technical support.
	Defective temperature sensor	Ask for technical support.
No flow or a leak of paraffin liquid	Wax is not fully melted due to insufficient time	Continue heating
	Magnetic valve is blocked or defective	Ask for technical support.
Leak of paraffin liquid, but the magnetic valve makes normal sound when it is opened.	The magnetic valve has other issues	Clean the dust on the surface; ask for technical support.
Light twinkling when it is turned on	Unstable power	Check the power line connection
Starts to heat when turned on but under the off-work mode	SSR is broken	Ask for technical support
Cryo plate		
Cryo plate cannot cool down	Poor power connection	Check the power line connection.
	Controller or compressor may be defective	Ask for technical support.
Cryo plate can cool down, but the temperature cannot reach to setting temperature	The fan does not work	Ask for technical support.
Cryo plate can cool down, but the temperature cannot reach to the setting temperature.	Insufficient refrigerating fluid	Ask for technical support.

8. LIMITED WARRANTY

What your warranty covers:

- Defects in materials or workmanship that occur under normal use and care.

For how long after your purchase:

- Two years from the date of purchase at retail.

What we will do:

- Repair or replace your product.

How you get service:

- Locate your serial number and model > contact our customer service at support@rankinbiomed.com to open a service ticket.

What your warranty does not cover:

- Damage from misuse or neglect
- Products purchased from non-authorized retailers, dealers, or resellers

Limitation of Warranty:

- The warranty stated above is the only warranty applicable to this product. All other warranties, expressor implied (including all implied warranties of merchantability or fitness for a particular purpose) are hereby disclaimed.
- Repair or replacement as provided under this warranty is the exclusive remedy of the consumer. The manufacturer shall not be liable for incidental or consequential damages resulting from the use of this product or arising out of any breach of any expressor implied warranty on this product. Any implied warranty of merchantability or fitness for a particular purpose on this product is limited to the applicable warranty period set forth above.