

OPERATOR MANUAL

Rankin Basics Semi-Automated Microtome MCT45



Attention: Before using the instrument, please read this Instruction carefully, and keep the Instruction for further reference.

Please refer to the nameplate on the back of the instrument for the serial number and manufacturing date of the instrument.

Table of Contents

- 1. OVERVIEW 3
- 2. SAFETY 4
- 3. TECHNICAL SPECIFICATIONS..... 6
- 4. UNPACKING, TRANSPORTATION, AND STORAGE 8
- 5. INSTALLATION..... 9
 - 5.1 Instrument placement/working site requirements 9
 - 5.2 Instrument components 9
 - 5.3 Assembling the specimen clamp 10
 - 5.4 Assembling the blade holder and base 12
 - 5.5 Assembling the section waste tray 12
 - 5.6 Electrical connection 12
- 6. OPERATION 13
 - 6.1 Function of Small Handwheel 13
 - 6.2 Control Panel 13
 - 6.3 Operation procedures 14
 - 6.4 Three sectioning modes 16
- 7. TROUBLESHOOTING 18
- 8. CLEANING AND MAINTENENCE 19
- 9. WARRANTY AND SERVICE 20
- 10. ACCESORY LIST..... 21

1. OVERVIEW

The Rankin Basics Semi-Automated microtome MCT45 is an electronically motorized rotary microtome for use in routine and research laboratories in the fields of biology, medicine, and industry.

It is designed for cutting both soft paraffin and harder specimens, as long as they are suitable for being cut manually or automatically. Any other use of the instrument is considered improper.

- This instrument may be operated by trained laboratory personnel only.
- All laboratory personnel designated to operate this instrument must read the Operator Manual carefully and must be familiar with all technical features of the instrument before attempting to operate it.

Front/side View

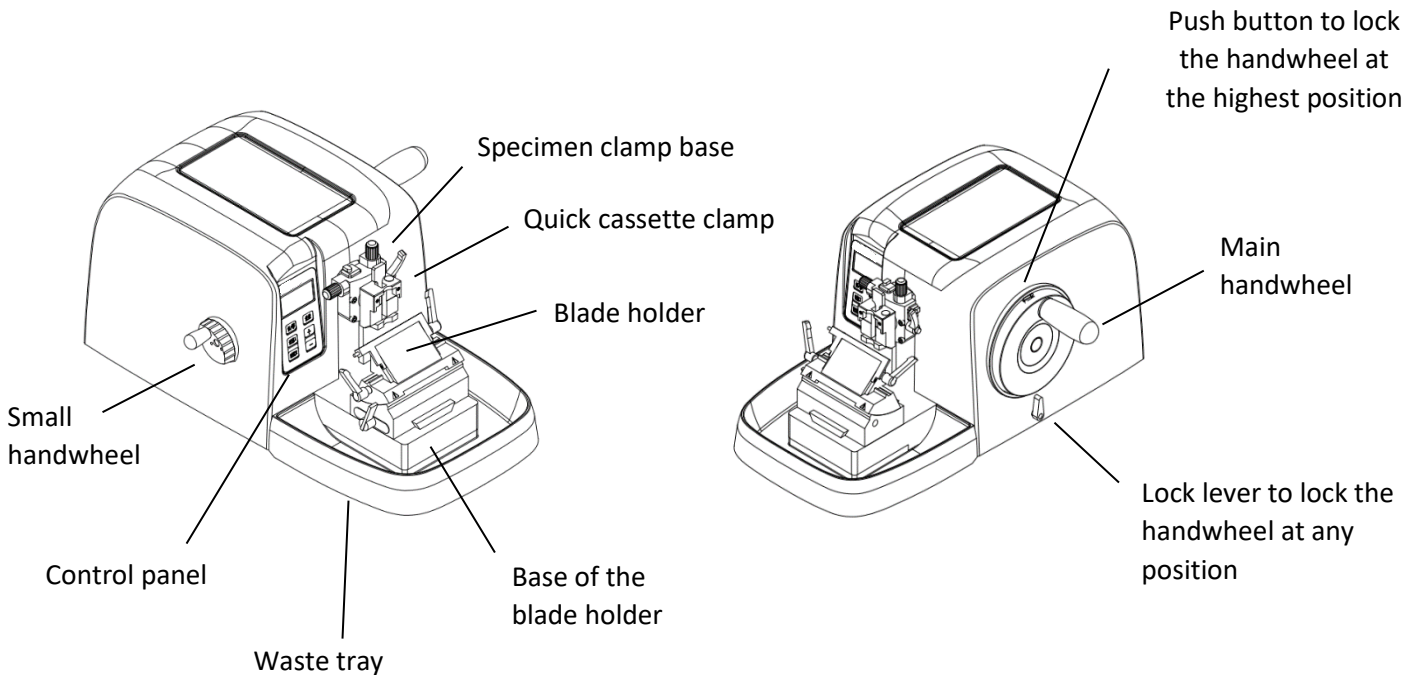

Back View

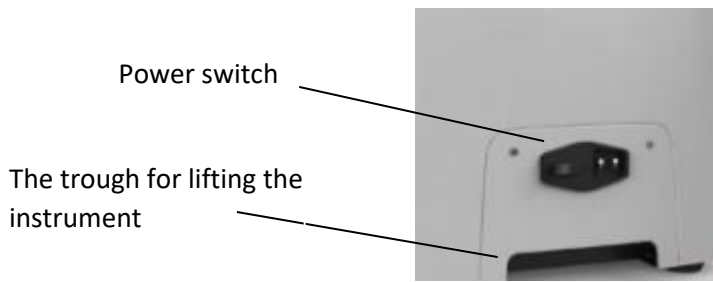

2. SAFETY

Be sure to comply with the safety instructions and warnings provided in this section.

Be sure to read these instructions, even if you are already familiar with the operation and use of other similar products.

Note: The safety devices installed in this instrument by the manufacturer only constitute the basis for accident prevention. Accident-free operation is, above all, the primary responsibility of the owner of the instrument and the designated personnel who operates, services, or cleans the instrument.

To ensure trouble-free operation of the instrument, make sure to comply with the following instructions and warnings.



Warnings – Transport and installation

- Once removed from the crate, the instrument may only be transported in an upright position.
- Never lift the instrument by the handwheels or the cassette clamp. Always remove the section waste tray before transporting the instrument.
- Connect the instrument to a grounded power socket only using one of the power cables provided (GB9706.1 Standard).
- Do not interfere with the grounding function by using an extension cord without a ground wire.
- Do not operate in rooms with explosion hazard.
- Exposure to extreme temperature changes between storage and installation locations and high air humidity may cause condensation inside the instrument. If this is the case, wait at least 2 hours before switching on the instrument. Failure to comply with this may cause damage to the instrument.
- The protective devices on both instrument and accessories must neither be removed nor modified.



Warnings – Personal safety precautions

When working with microtomes, personal safety precautions must always be taken. It is mandatory to wear work safety shoes, safety gloves, a mask and safety goggles.



Warnings – Operating the instrument

- Be very careful when handling microtome knives and disposable blades because their cutting edge is extremely sharp.
- Always remove the knife / blade before detaching the knife holder from the instrument. Always put the knives back into the knife case when not in use.
- Never place a knife anywhere with the cutting edge facing upwards and never try to catch a falling knife!
- Always clamp the specimen block PRIOR TO clamping the knife or blade.
- Lock the handwheel and cover the knife edge with the knife guard prior to any manipulation of knife or specimen clamp, prior to changing the specimen block and during all work breaks!
- Always take appropriate safety precautions when sectioning brittle specimens because the specimen may splinter.
- Ensure that liquids do not enter the interior of the instrument during work.
- Do not attempt to clamp, approach, or orient the specimen during the retraction phase.
- Prior to sectioning, check that the specimen is securely clamped in the specimen clamp –failure to observe this poses the risk of damaging the specimen.



Warnings – Cleaning and Maintenance

- LOCK the handwheel before each cleaning.
- Before each cleaning, switch off the instrument, disconnect the power plug, remove the knife holder completely and clean it separately.
- Always remove the blade before detaching the knife holder from the instrument.
- Do not use any solvents containing acetone or xylene for cleaning.
- Ensure that no liquids enter the interior of the instrument when cleaning.
- Do not turn the instrument on before it is completely dry.
- Turn the instrument off with the main switch and pull the main plug before replacing the fuses. Only use fuses of the same specification provided in Operation Manual.
- Only authorized and qualified service personnel may access the internal components of the instrument for service and repair.

3. TECHNICAL SPECIFICATIONS

Section thickness range : 0.25 to 100 µm

0.25—2.5 µm ; Increments of 0.25 µm

2.5—5 µm ; Increments of 0.5 µm

5.0—10 µm ; Increments of 1 µm

10—30 µm ; Increments of 2 µm

30—60 µm ; Increments of 5 µm

60—100 µm ; Increments of 10 µm

Trimming thickness range : 1 to 600 µm

1—10 µm ; Increments of 1 µm

10—20 µm ; Increments of 2 µm

20—50 µm ; Increments of 5 µm

50—150 µm ; Increments of 10 µm

150—600 µm ; Increments of 50 µm

Retraction range : 0 to 100 µm

“0” means that the retraction function is off.

0-20 µm ; Increments of 5 µm

20-100 µm ; Increments of 10 µm

Full section interval span : 10 to 6000 µm

10-12-15-20-25 5000--6000 µm

Number of sectioning : 0 - 9999

Number of trimming : 0 - 9999

Horizontal feed : 30 mm

Running speed : 4,000 µm/s

Vertical stroke : 70 mm

Specimen Clamp Rotation: Left and right/up and down. At any angle within 360 degrees (optional)

Movement Range of the Base of Blade Holder Base: 0-60 mm (front to back)

Lateral movement Range of the blade clamp: 20 mm

Small handwheel control direction: two options

Fine (precise) trimming function: On or Off

Memory position of the clamp: two position set

GENERAL SPECIFICATIONS

Working Voltage: AC100V~120V/AC210V~240V

Frequency : 50Hz/60Hz

Power : 100W

Fuse: F3A L 250V

Use environment : +18~25°C

Relative humidity allowed: < 80%

Atmospheric pressure allowed: 860 hpa~1060 hpa

Dimensions: 478 mm x 410 mm x 310 mm (L x W x H)

Weight: 66 lbs

4. UNPACKING, TRANSPORTATION, AND STORAGE

4.1 Unpacking

- Open the crate, take out all accessories and user manual. Note: The transport crate and included retaining elements should be kept in case a return shipment is necessary later.
- Lift the instrument by holding it by the base plate and under the instrument on the back (marked by blue circles in the pictures below) and lift it out of the formed cushion.



Do not hold the main and small handwheels and handles to lift the instrument!

4.2 Transportation

To guarantee trouble-free function of the instrument after transportation, please follow the instructions below for transportation:

- Shutting down the instrument for transportation: turn off the instrument, unplug the unit.
- Remove all section waste debris and movable parts from the instrument.
- Clean and disinfect all accessories according to the respective applicable lab regulations and transport them in dry condition.
- Unscrew the handwheel handle for transportation if necessary.

Note

Use original packaging materials for transportation of the instrument. If the original packaging is no longer available, please contact customer service via support@rankinbiomed.com.

4.3 Storage

Storage conditions:

Storage environment: 0°C~40°C

Relative humidity should be lower than 80%

Atmospheric pressure 860hpa~1060hpa

Clean room without corrosive gas and well ventilated

5. INSTALLATION

5.1 Instrument placement/working site requirements

- Place the instrument on a stable laboratory table.
- Room temperature permanently between + 10 °C and + 35 °C.
- Obstruction-free access to the handwheel.



Never operate the instrument in rooms with explosion hazard.

5.2 Main instrument components

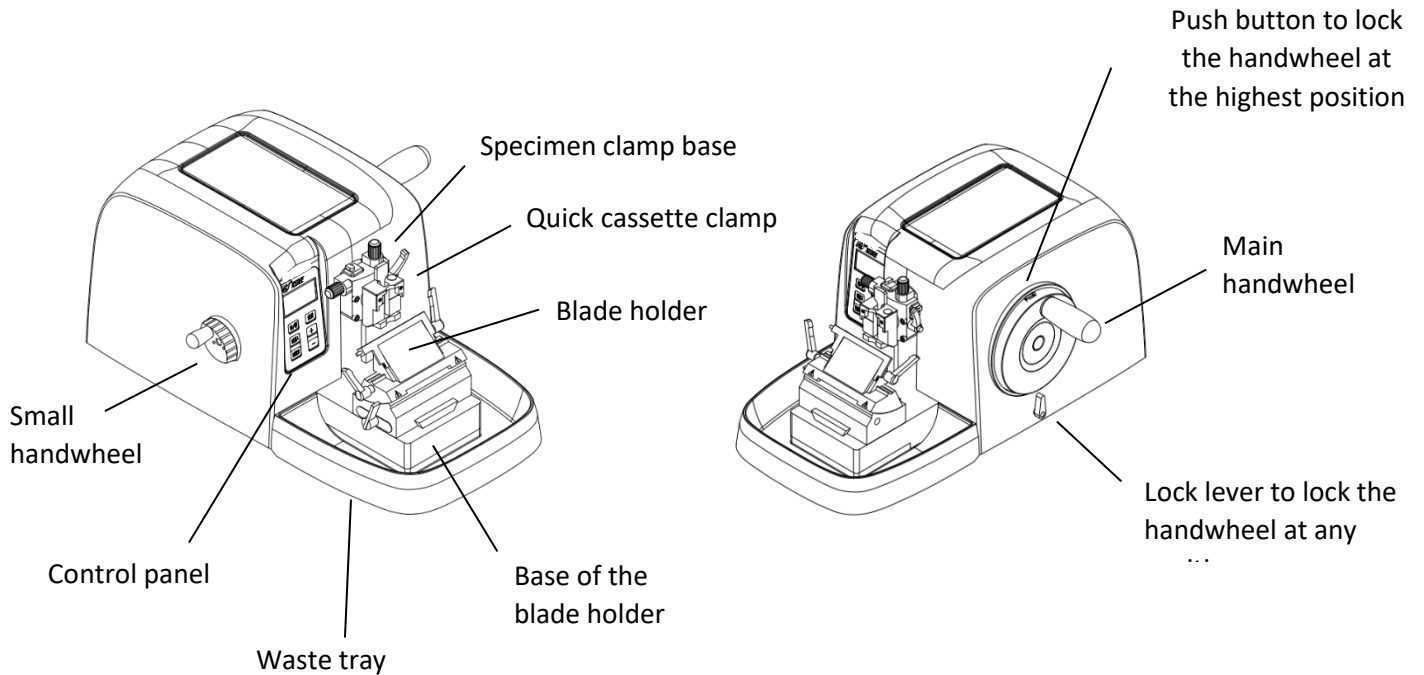

5.3 Assembling the Specimen Clamp

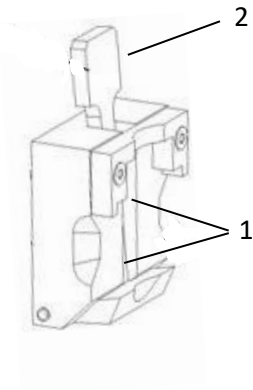

Quick Cassette Clamp

1. Two clamp fixation holes
2. Quick cassette release lever

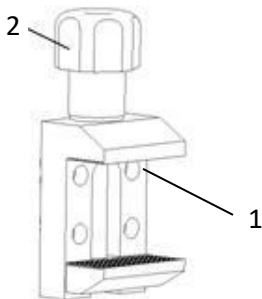

Standard Specimen Clamp

1. Four clamp fixation holes
2. Clamp lock knob

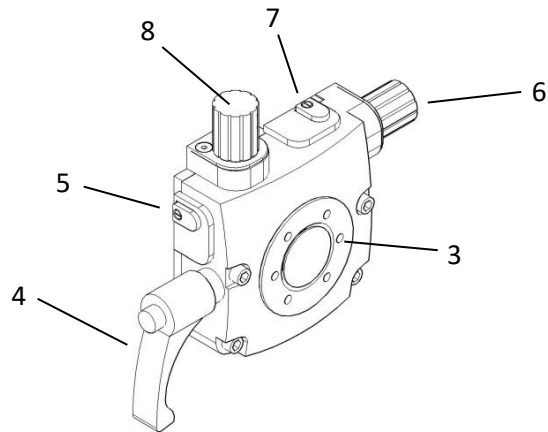

Specimen clamp base

3. Clamp fixation screw holes
4. Clamp lock lever
5. Specimen tilt adjustment indicator
6. Vertical adjustment knob for specimen tilt
7. Horizontal adjustment indicator
8. Horizontal adjustment knob

If the specimen clamp is not installed in the instrument or the user needs to install a new one, please follow the procedures below:

- Lock the handwheel.
- First lock the clamp lock lever (4), align the two holes (for quick cassette clamp) or four holes (for standard specimen clamp) of the clamp (1) with the screw holes of the base (3), and then tighten the screws.
- Loosen the clamp lock lever (4).
- The specimen tilt adjustment indicator (5) in the highest position indicates that the specimen clamp is in the central position in the vertical direction. Turn the vertical adjustment knob for specimen tilt (6) to adjust the tilt angle of specimen clamp.
- The horizontal adjustment indicator (7) in the highest position indicates that the specimen clamp is in the central position in the horizontal direction. Turn the horizontal adjustment knob (8) to adjust the horizontal position of specimen clamp.
- Once the specimen clamp is adjusted to the desired position, lock the clamp lock lever (4).
- Move the quick cassette release lever (2) forward to place the specimen cassette in either direction (as shown in the picture below), and then move the quick cassette release lever (2) backward to fix the cassette.

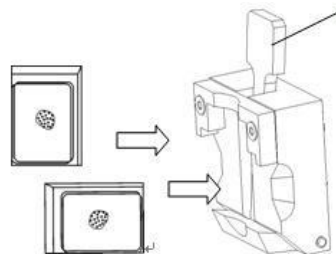

5.4 Assembling the blade holder and base



Do not insert the disposable blade when the blade holder is not firmly installed! ALWAYS remove the disposable blade before replacing the blade holder.

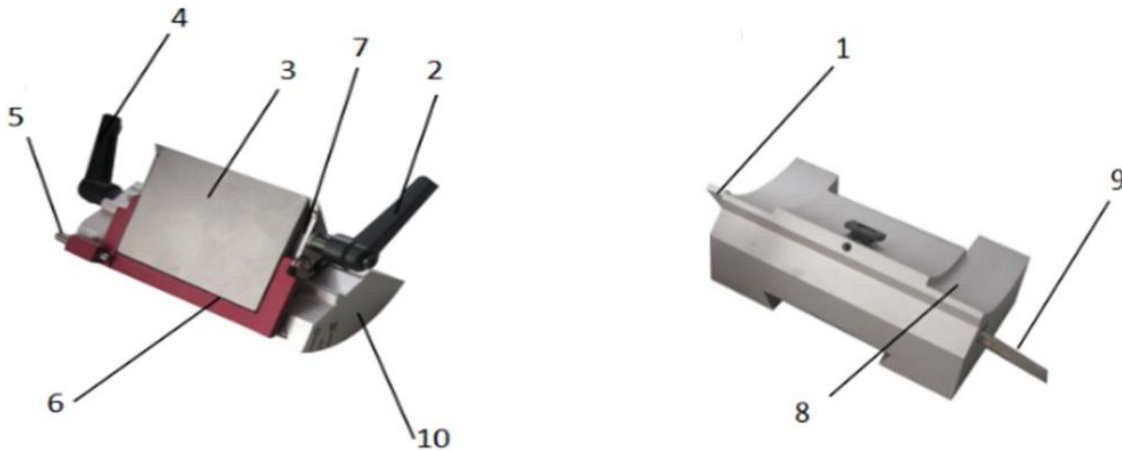

Steps:

1. Turn the **lateral movement lever (4)** counterclockwise to assemble the **blade holder top (6)** onto the **segment arc (10)**, which is then locked by turning the **lateral movement lever (4)** clockwise.
2. Use an Allen wrench to loosen the **segment arc screw (9)** and assemble the **segment arc (10)** of the blade holder onto the **base (8)**
3. After properly adjusting the angle (about 5°-8°), tighten the **segment arc screw (9)** to firmly fix the assembly.
4. When installing the disposable blade, loosen the **blade lock lever (2)**, insert and push the blade into the slot from the side, then tighten the **blade lock lever (2)**.
5. When replacing the blade, first loosen the **blade lock lever (2)**, pull up the **blade guard (6)**, push the **ejection button (5)** to remove the blade.

5.5 Assembling the Section Waste Tray

The waste tray can be installed horizontally along the base and pushed from the outside to the inside.

5.6 Electrical connection

Insert the power plug provided in the package into the connecting jack on the rear of the instrument.

6. OPERATION

6.1 Function of Small Handwheel on the left side of the instrument

The direction can be set according to the user's habit using the SET key (See Page 11)

Option 1: rotating forward to fast advance and rotating backward to fast retraction;

Option 2: rotating forward to fast backward and rotating backward to fast forward.

6.2 Control Panel

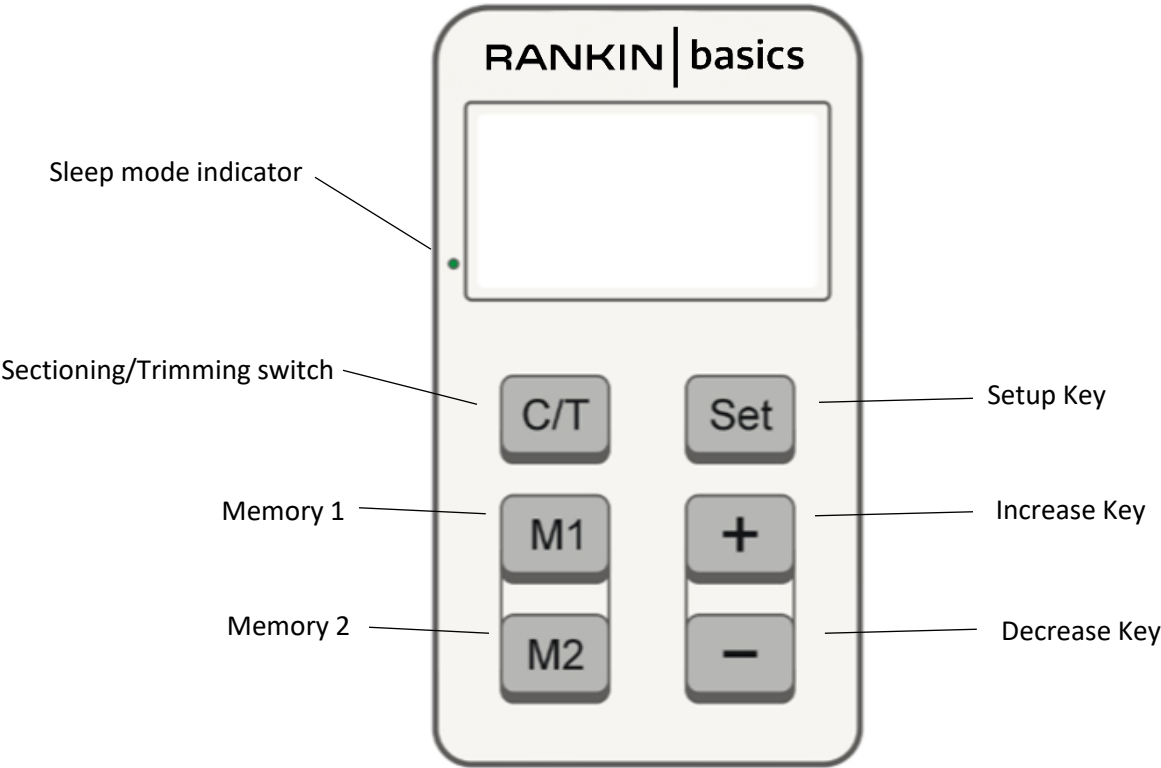

Brief function descriptions

Sectioning/ Trimming Switch (C/T): switch between sectioning and trimming.

Memory 1 (M1): Press to return to the saved position. Hold (M1) to set the first position.

Memory 2 (M2): Press to return to the saved position. Hold (M1) to set the second position.

Decrease key (-): Reduce the sectioning thickness value (hold for rapid decrease)

Increase Key (+): Increase the sectioning thickness value (hold for rapid increase)

Setup Key (SET): Press to open the option menu for sectioning thickness, trimming thickness, retraction distance, interval range, selection of precise/fine trimming and buzzer prompt, and small handwheel course feed direction. Hold to cyclically switch between three modes (SMART MODE, FULL MODE, STANDARD MODE).

6.3 Operation Procedures

1. Hold the “SET” key to switch between the following three modes: FULL MODE, STANDARD MODE, and SMART MODE (See Page 14 for detailed descriptions).

FULL MODE		STANDARD MODE		SMART MODE	
Section	3.00 μ m	Section	3.00 μ m	Section	3.00 μ m
Trimming	20 μ m	Trimming	20 μ m	Trimming	20 μ m
\updownarrow 10	∇ 35/200	\updownarrow 10		\updownarrow 10	

2. Click the “SET” key to enter the following setting interface:

OPTION		OPTION		OPTION	
Section	3.00 μ m	Range	100 μ m	Feed	/C 500 μ m
Trimming	20 μ m	Precise	<input checked="" type="checkbox"/>		
Retract	10 μ m	Direction			

3. Short click the “SET” key to enter different items and press the “+” or “-” keys to set up the following items: section thickness, trimming thickness, retraction distance, interval range, selection of fine trimming and buzzer prompt, and small handwheel course feed direction.

Regarding selection of fine trimming and buzzer prompt, four options are displayed on the screen and can be selected by pressing the “+” or “-” keys:

- No fine trimming; with buzzer prompt
- Fine trimming; with buzzer prompt
- Fine trimming; no buzzer prompt
- No fine trimming; no buzzer prompt
- No fine trimming; no buzzer prompt

4. After the setting is completed, press the “C/T” key to exit the setting interface. Rotate the main handwheel for sectioning or trimming as needed.



When feeding is exceeding the allowable range, the motor will automatically stop running and give a beeping alarm. Under this situation, please turn the Small Handwheel in the opposite direction to return.

Note: 1. The rotation of the handwheel should be even, and the rotation speed should be compatible with the hardness of the specimen. The speed should be slower when sectioning harder specimens.

2. To ensure satisfactory section quality, the recommended practice is to evenly rotate the handwheel clockwise for a full circle.

5. After operation, the Main Handwheel should be returned to the starting position and locked. The push button on the handwheel is to lock the Specimen Clamp in the upper position, and the lock lever at the bottom of the instrument is to lock the Specimen Head at any position.



Note:  = lock ;  = unlock



6. Carefully remove the blade from the holder and place it in the blade box following the laboratory safety regulations. Take the specimen out from the clamp. Remove the section debris from the instrument. Remove the waste tray and clean up the waste debris.

7. The instrument will automatically enter the sleep standby state after it is not operated for 5-6 minutes, as indicated by the sleep mode indicator light. The instrument returns to the working state by gently moving the handwheel or pressing any button.

Note: To extend the life of the instrument, please turn off the power so that the instrument does not stay in the standby mode for an excessively long period of time.

6.4 Three sectioning modes

SMART MODE

In this mode, sectioning and trimming can automatically switch by rotating the main handwheel either half a circle (i.e., “rock”) for trimming (the screen cursor will stay at the trimming value) or a full circle for sectioning (the cursor will stay at the sectioning value). In the interface below,  indicates retraction and “10” indicates the retraction distance is 10 μm .  indicates the instrument is in the fine trimming process and this icon will disappear when fine trimming is completed. “Section” and “Trimming” shows the actual numbers of sectioning or trimming (the maximum value is 9999). If buzzer prompt is set, the instrument will beep to warn the completion of fine trimming.

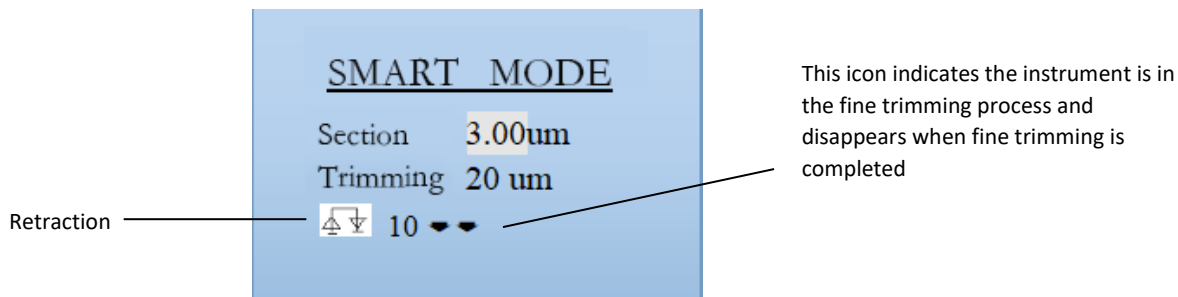

FULL MODE

This mode, also called full-layer interval sectioning, is often used to investigate the tissue structure at different depths, generating “3D” images. Under this mode, the tissue sample is sectioned according to the depth settings automatically. Fast advance and retraction can be achieved by using the small handwheel.

The typical operation steps are as following:

1. Click the “C/T” key to section and then trim.
2. The cutting mode will automatically switch to sectioning once the sample is trimmed to the preset depth, as indicated by buzzer prompt.
3. The above steps can be repeated by pressing the “C/T” key again.

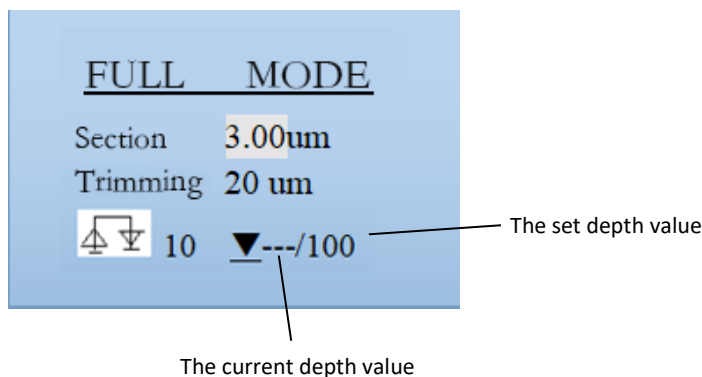

STANDARD MODE

Similar to the operation procedures on a conventional microtome, use the small handwheel for fast advance and retraction, and click the “C/T” key to switch between sectioning and trimming. The sectioning/trimming thickness can be adjusted by using the “+” and “-” keys. When rotating the main handwheel, the specimen will be sectioned or trimmed as indicated by the cursor on the screen.

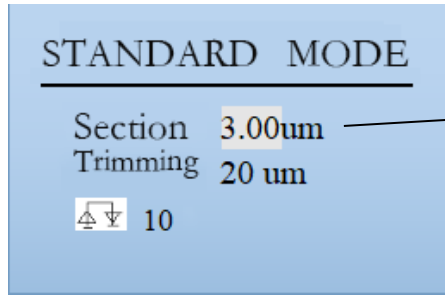

The location of the cursor indicates that the sample is sectioned at a thickness of 3 μm .

7. TROUBLESHOOTING

Problem	Cause	Suggestion
<p>Thick/thin sections:</p> <p>The sections alternate between being thick and thin, or there is chattering in the sections, or the specimen is torn out of the embedding.</p> <p>In extreme cases, there are no sections whatsoever.</p>	<ol style="list-style-type: none"> 1. Blade, knife holder or orientation is not clamped properly. 2. The specimen is not clamped properly. 3. The blade is dull. 	<ol style="list-style-type: none"> 1. Re-clamp the blade, knife holder or orientation. 2. Check whether the cassette is securely clamped. <ul style="list-style-type: none"> • Clean the cassette. • Use other types of cassettes if the cassette is deformed or its dimensions are not within the specified tolerances. • The cassette clamp is configured incorrectly or is defective. In this case, have Technical Service inspect and reconfigure the clamp. 3. Laterally displace the knife holder or insert a new blade.
<p>Section compression:</p> <p>The sections are very compressed, show folds or are squeezed together.</p>	<ol style="list-style-type: none"> 1. The blade is dull. 2. The specimen is too warm. 3. The sectioning speed is too fast. 	<ol style="list-style-type: none"> 1. Use another area of the blade or a new blade. 2. Cool the specimen before sectioning. 3. Reduce the sectioning speed.
<p>Noises during sectioning:</p> <p>The blade "squeaked " when sectioning hard specimens. The sections show scratches or chatter marks.</p>	<ol style="list-style-type: none"> 1. The sectioning speed is too fast. 2. The clearance angle is too wide. 3. Insufficient clamping of specimen clamp and/or blade holder. 	<ol style="list-style-type: none"> 1. Reduce the sectioning speed. 2. Methodically reduce the clearance angle setting until you have found the optimum angle. 3. Check all screw and clamp connections on the specimen holder system and the knife holder. If necessary, tighten the levers and screws.
<p>Feed motion no longer occurs.</p> <p>The cutting motor cannot be started.</p>	<p>The specimen has reached the extreme position of the front end.</p>	<p>When the specimen has reached the extreme position of the front end, an alarm will be issued. Rock the small handwheel to return the specimen to the beginning.</p>
<p>The screen is not illuminated and no display when you turn on the switch.</p>	<ol style="list-style-type: none"> 1. The wire of the display is loose. 2. The fuse is blown. 	<ol style="list-style-type: none"> 1. Have Technical Service check the connection of the wire. 2. Change fuse.

8. CLEANING AND MAINTENANCE



Warnings

- Always remove the blade before detaching the blade holder from the instrument.
- Always put the knives/blades back into the knife case when not in use. Never place a knife anywhere with the cutting edge facing upwards and NEVER try to catch a falling knife!
- When using cleaners, comply with the safety instructions of the manufacturer and the laboratory safety regulations.
- When cleaning the outer surfaces, do not use xylene, scouring powders or solvents containing acetone or xylene. Xylene or acetone will damage the finished surfaces.
- Ensure that liquids do not enter the interior of the instrument during cleaning.

8.1 Cleaning

Before each cleaning:

- Raise the specimen clamp to the upper end position and activate the handwheel lock.
- Switch the instrument off and unplug it.
- Remove the blade from the blade holder and insert it into a safe dispenser or other safe place.
- Remove knife holder base and knife holder for cleaning.
- Remove the specimen from the specimen clamp.
- Remove section waste with a dry brush.
- Remove specimen clamp and clean separately.

Instrument and outside surfaces

- If necessary, the varnished outside surfaces of the control panels can be cleaned with a mild commercial household cleaner or soap water and then be wiped with a moist cloth.
- To prevent paraffin from sticking to the surface, paraffin repellent can be used; to remove paraffin residue, xylene substitutes, paraffin oil, or paraffin removers can be used.
- The instrument must be completely dry before it can be used again.

Blade holder

- Take the blade holder apart for cleaning.
- Clean all parts of the holder. For cleaning and removal of paraffin, do not use xylene or cleaning fluids containing alcohol (e.g., glass cleaner).
- Dry the holder and reassemble.
- After cleaning the moving parts, apply a thin coat of good quality lubricant oil to them.

9. WARRANTY AND SERVICE

The manufactory guarantees that the contractual product delivered has been subjected to a comprehensive quality control procedure based on the in-house testing standards, and that the product is faultless and complies with all technical specifications and/or agreed characteristics warranted.

As the product is constantly updated, we reserve the right to update the product without prior notice.

What your warranty covers:

- Defects in materials or workmanship that occur under normal use and care.

For how long after your purchase:

- Two years from the date of shipment.

What we will do:

- Repair or replace your product.

How you get service:

- Locate your serial number and model > contact our customer service at support@rankinbiomed.com to open a service ticket.

What your warranty does not cover:

- Damage from misuse or neglect
- Products purchased from non-authorized retailers, dealers, or resellers

Limitation of Warranty:

- The warranty stated above is the only warranty applicable to this product. All other warranties, expressor implied (including all implied warranties of merchantability or fitness for a particular purpose) are hereby disclaimed.
- Repair or replacement as provided under this warranty is the exclusive remedy of the consumer. The manufacturer shall not be liable for incidental or consequential damages resulting from the use of this product or arising out of any breach of any expressor implied warranty on this product. Any implied warranty of merchantability or fitness for a particular purpose on this product is limited to the applicable warranty period set forth above.

10. ACCESSORY LIST

Description	Qty.	Special Note
Base Unit	1	
Disposable Blade Holder	1	2-in-1 low and high profile
Power cord	1	
Dust Cover	1	
Fuse	1	
Operator Manual	1	