



Accu-Cut[®] SRM[™] 200

Rotary Microtome

**Operating
Manual**

© 2010 Sakura Finetek U.S.A., Inc.

All Rights Reserved
Printed in U.S.A.



Manufactured for:

Sakura Finetek USA, Inc., Torrance, CA 90501, U.S.A.











Sakura Finetek Japan Co., Ltd., Tokyo, 135-0007, Japan

Sakura Finetek Europe B.V., 2408 AV Alphen aan den Rijn, NL

Made in U.S.A.

0000107-03 Rev. B

TABLE OF CONTENTS

<i>Section</i>	<i>Page</i>
IMPORTANT INFORMATION	4
1 INTRODUCTION	
Basic Instrument - General view	5
General Description	6
Safety Instructions	7
SPECIFICATIONS	10
2  INSTALLATION	
General Information	11
Unpacking Instructions	11
Installation Site Requirements	11
3  OPERATING INSTRUCTIONS	
Inserting the Specimen Clamp	13
Direct Fitting of the Specimen Clamp onto the Orientation Attachment	13
 Inserting the Specimen Block	14
Mounting the Blade Holder Base Assembly	14
Mounting the Holder for Disposable Blades	14
Inserting Disposable Blades	15
 Adjusting the Clearance Angle	15
Orienting the Specimen	16
 Specimen Trimming with the Coarse Feed Wheel	17
Trimming with the Mechanical Trimming Lever	18
Sectioning	19
 Inserting and Removing Specimens	19
 End of Day Protocol	19
4  USING THE ACCESSORIES	
Specimen Clamps and Inserts	21
Blade Holder Base Assembly	22
Holder for Reusable Knives	23
 Holder for Disposable Blades	24
Adjusting the Front Adapter Plate	25
5  CARE OF THE INSTRUMENT	
Cleaning	27
Disposal	27
Maintenance	28
6 TROUBLESHOOTING	29
7 SERVICE	31
INDEX	32

NOTE: The  symbol warns against operating procedures that could be dangerous for either the user or the instrument.

IMPORTANT INFORMATION

Always keep this manual near the instrument. Read it carefully before operating the instrument.

Serial No.: _____
Installation Date: _____
Manufactured for: Sakura Finetek U.S.A., Inc. and Sakura Finetek Europe B.V.

The model and serial numbers are specified on the nameplate on the left side of the instrument.



Be sure to fill in the Warranty Registration Card that can be found at the front of this manual. Send it immediately to ensure proper activation of the warranty.

The Accu-Cut® SRM™ 200 is a manually operated retracting rotary microtome for the preparation of thin sections in routine and research histology applications.

This instrument is designed to section soft materials embedded in paraffin as well as harder specimens, provided those specimens are still suitable for manual sectioning.

Any other use of this instrument is considered improper operation.

Prior to operating the instrument, carefully read this entire manual.

The  symbol warns against operating procedures that could be dangerous either for the user or the instrument. Additional information, explanations, or recommendations which are useful to the operator are marked by .

This instrument may only be operated by skilled personnel and may only be used for the application described in this manual. The instrument may only be operated in accordance with the instructions given in this manual.

The instrument may only be used with the accessories and tools described in this manual.

Repairs must be carried out only by qualified service personnel authorized by Sakura Finetek.

Due to a policy of continuous improvement of our products, Sakura Finetek reserves the right to change specifications without notice.

Sakura Finetek U.S.A., Inc.

Torrance, CA 90501
USA

Telephone: **310-972-7800** or

800-725-8723

Fax: 310-972-7888

Sakura Finetek Europe B.V.

2408 A V Alphen aan den Rijn
The Netherlands

Telephone: **+31-(0)88-59.20.000**

Telefax: **+31-(0)88-59.20.001**

www.sakura.eu

Basic Instrument - General view

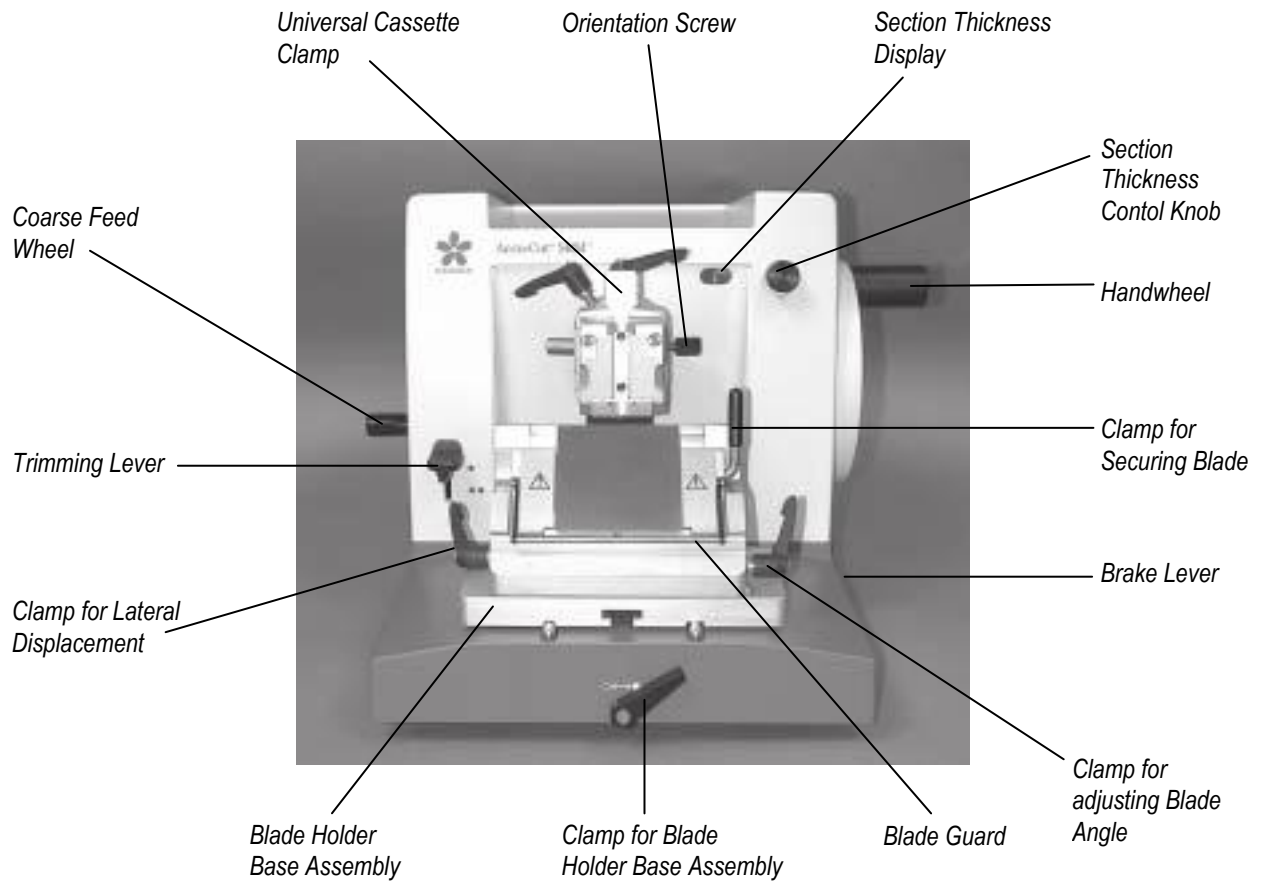

INTRODUCTION

General Description

The Accu-Cut® SRM™ 200 is a manually operated retracting rotary microtome.

The advance and vertical stroke mechanisms of the Accu-Cut SRM 200 run on cross roller guides which are free from backlash and are maintenance-free. A housing protects the entire micrometer feeding mechanism.

Sectioning is done manually by rotating the smooth-running hand-wheel in the clockwise direction. Section thickness is selected by turning a control knob. The coarse feed function is operated by the coarse feed wheel. The instrument also features a mechanical trimming function, which is activated by pressing a lever.

An additional feature is specimen retraction, designed to protect both knife or blade, and specimen. The retraction phase coincides with the return stroke of the specimen to the starting position for the next cutting stroke. During the retraction phase, the specimen is pulled back from the blade by 220 μm . Prior to the next section thickness advance, the specimen advances by the retraction value.



Never orient a specimen during the retraction phase as the specimen will advance by the retraction value plus the selected section thickness! Due to that fact, there is a risk that both specimen and cutting edge may be damaged!

The Accu-Cut® SRM™ 200 (Part No. 1429) is a preconfigured, ready-for-use system with mechanical trimming function, coarse feed, retraction feature, and is equipped with the following accessories:

Qty	Item	Product Code
1	Blade Holder Base Assembly	1434
1	Holder for Low Profile Disposable Blades*	1435
	or	
1	Holder for High Profile Disposable Blades*	1469
1	Low Profile Back-Plate (included in 1435)	1437
1	Orientation Attachment for Clamps	1438
1	Universal Cassette Clamp with Adapter	1439
1	Maintenance Kit,	1440
	consisting of:	
	1 Allen key, size 4	
	1 Allen key, size 3	
	1 Microtome Oil, 50 ml (type 405)	1447
	2 Screwdrivers	
1	Dust Cover	1441
1	Operating Manual	0000107-01

*The SRM™ 200 will be packaged with either a disposable blade holder for low profile blades (1435) or a disposable blade holder accommodating high profile blades (1469), if specified.

The following optional accessories are also available:

Item	Product Code
Holder for Reusable (Steel) Knives	1442
Fixed Attachment for Clamps	1443
Standard Specimen Clamp, 40 x 40 mm	1444
Standard Specimen Clamp, 50 x 55 mm	1445
V-Insert	1446
Cold Plate (24/cs)	4650
Microtome Waste Collection System (w/25 bags)	4657
Waste Collection Bags (250/cs)	4658

Compare the delivered items with the parts list and your order. If you find any discrepancies, immediately contact your Sakura Finetek distributor or Sakura Finetek directly.

To ensure optimum performance of the Accu-Cut SRM 200 rotary microtome, the following disposable blades are recommended:

Item	Product Code
Accu-Edge® Low Profile Blade Dispenser 50/pkg, 10 pkg/cs	4689
Accu-Edge® High Profile Blade Dispenser 50/pkg, 10 pkg/cs	4685

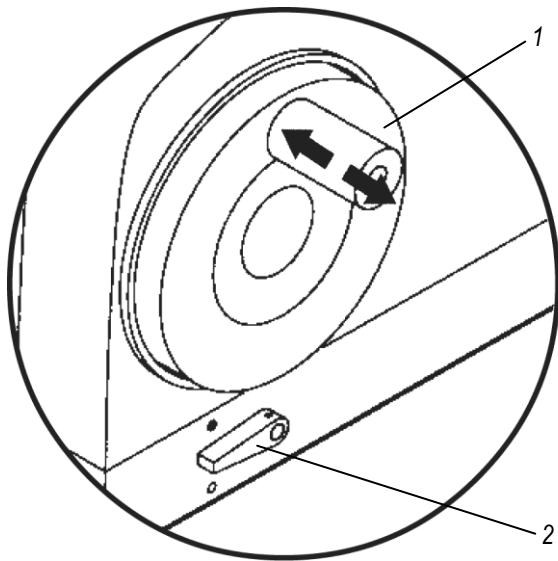

● = locked
○ = released

Fig. 1-1

Safety Instructions



The safety devices on the instrument and on the accessories must not be removed or modified! Always lock the handwheel and cover the cutting edge with the blade guard prior to manipulating the blade and specimen, changing the specimen, or when the instrument is not in use.

This instrument is equipped with the following safety devices: handwheel locking system, handwheel brake, and blade guard on all blade holders.

Activating the handwheel locking system

The handle (1) of the sectioning handwheel can be used to lock the handwheel in the 12 o'clock position (Fig.1-1). To rotate the handwheel, the handle has to be pulled outward. As soon as the handle is pushed inward, the handwheel will be locked mechanically when reaching the 12 o'clock position.

Performance check

- To lock the handwheel, push the handle (1) toward the instrument.

The handwheel remains locked in the 12 o'clock position and cannot be rotated.

- To unlock the handwheel, pull the handle (1) away from the instrument.

The handwheel can then be rotated again.

Activating the handwheel brake

Using the lever (2) located on the right side of the microtome base, the handwheel brake can be activated with the handle in any position. The "release" and "lock" positions of the brake lever are marked with two symbols on the microtome base plate (● = locked; ○ = released) (Fig. 1-1).

NOTE: The brake does not lock the handwheel in any position. The brake slows down movement of the handwheel (or prevents easy movement of the handwheel). The brake is a friction brake. It keeps the specimen clamp from moving up and down

INTRODUCTION

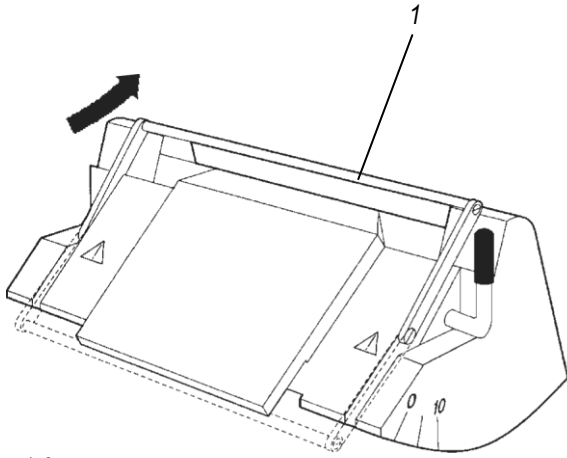

Fig. 1-2

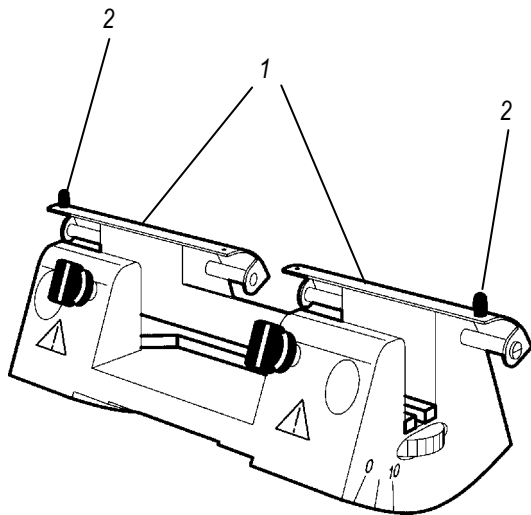

Fig. 1-3

Knife / Blade Guards



Always lock the handwheel and cover the cutting edge with the blade guard prior to manipulating the blade and specimen, changing the specimen, or when the instrument is not in use.

Every blade holder is equipped with a permanent blade guard (1) (Fig. 1-2 and 1-3), which covers the entire length of the blade edge in any position.

Holder for disposable blades

The blade guard system of the blade holder (Fig. 1-2) consists of a hinged bar (1). To cover the blade edge, tilt the bar (1) upward. The guard can be easily repositioned from the base of the blade holder to the blade edge as shown in Fig. 1-2.



The top of the fixing plate is sharp.

Holder for reusable knives (optional)

The knife guard of the knife holder (Fig. 1-3) can be easily positioned using the two buttons (2).

To cover the knife edge, slide both cover strips of the knife guard toward the center.



Transport and installation

- Please make sure to carefully read the Specifications in Section 1.
- The instrument may only be transported in an upright position.
- To move the instrument, do not grasp it by the handles of the sectioning or coarse feed wheel.
- The Accu-Cut® SRM™ 200 is a precision instrument and must be handled accordingly. Rough handling or dropping the instrument will disturb or damage internal components. Always handle the instrument with care.
- The safety devices on the instrument and on the accessories should not be removed or altered in any way.



Operating the instrument

- Be very careful when handling microtome knives or disposable blades. Their cutting edges are extremely sharp and can cause severe injuries.
- Never leave knives or holders with disposable blades inserted lying around without protection.
- Never place a knife on any surface with the cutting edge facing upwards.
- Never try to catch a falling knife or blade.
- Always clamp the specimen before inserting the blade.
- Always lock the handwheel and cover the cutting edge with the blade guard prior to manipulating the blade and specimen, changing the specimen, or when the instrument is not in use.
- Never orient a specimen during the retraction phase because the specimen will advance by the retraction value plus the selected section thickness.
Due to that fact, there is a risk that both specimen and blade may be damaged.
- Always wear safety goggles when sectioning brittle specimens. Specimens may splinter.



Cleaning

- Before cleaning the instrument, lock the handwheel and remove the blade.
- Avoid harsh solvents such as acetone which will damage the surface of the microtome and rubber/vinyl parts.
- Make sure that liquid does not get into the interior of the instrument while cleaning.
- When using detergents, comply with the safety instructions of the manufacturer and with all applicable regulations in your laboratory.



Maintenance

- Use a small brush to remove paraffin shavings.
- Maintenance and repair work may only be carried out by a qualified service technician, authorized by Sakura Finetek.

INTRODUCTION

SPECIFICATIONS

ENVIRONMENTAL

Operational Temperature: +10°C to +40°C
(50°F to 104°F)

PHYSICAL

Dimensions in cm: 40.0 (W) x 47.0 (D) x 29.5 (H)
Dimensions in inches: 15.8 (W) x 18.5 (D) x 11.6 (H)
Working height in cm: 10.5
Working height in inches: 4.1
Weight (without accessories): 29 kg (64 lbs.)
Weight (shipping): 34 kg (85 lbs.)

APPLICATION

Paraffin embedded
specimens for routine and
research histology

PARAMETERS

Section Thickness Range: 0.5 - 60 μm
Section Thickness Selection
Increments:
- From 0 to 2 μm in 0.5 μm
- From 2 to 10 μm in 1 μm
- From 10 to 20 μm in 2 μm
- From 20 to 60 μm in 5 μm
Coarse Feed Advance:
Horizontal Specimen
Advance: 25 mm
Vertical Specimen Stroke
Length: 59 mm
Specimen Retraction: 220 μm
Clearance Angle for Blade
Holder: 0-10°
Specimen Orientation:
Horizontal: 8°
Vertical: 8°
Rotation: 90°
Micron Thickness Setting: Adjustable with visual display
Trimming Steps: 10 μm , 50 μm
Displacement of
Blade Holder Base:
North/South:
(Vertically) Maximum: 55 mm
With all adapters attached:
40 mm
East/West:
(Horizontally) 45 mm

General Information

The Accu-Cut® SRM™ 200 is a precision instrument and must be handled accordingly. Rough handling or dropping the instrument will disturb or damage internal components. Always handle the instrument with care. Move the instrument by grasping the front and the back area at the base of the microtome.



This instrument is heavy; therefore, it is strongly recommended that it be lifted and transported by at least two people.



To move the instrument, do not grasp it by the handles of the sectioning or coarse feed wheel.

All of the accessories included with the microtome are packaged inside the shipping box.

- 1 Blade Holder Base Assembly (#1434)
- 1 Holder for Low Profile Disposable Blades (#1435)
or
- 1 Holder for High Profile Disposable Blades (#1469)
- 1 Low Profile Back-Plate (#1437)
(part of #1435)
- 1 Orientation Attachment for Clamps (#1438)
- 1 Universal Cassette Clamp with Adapter (#1439)
(attached to Accu-Cut® SRMTM 200)
- 1 Maintenance Kit (#1440) containing:
 - 1 Allen Key, size 4
 - 1 Allen Key, size 3
 - 1 Microtome Oil, 50 mL (type 405)
 - 2 screwdrivers
- 1 Dust Cover (#1441)
- 1 Operating Manual (#0000107-01)

Unpacking Instructions

1. Remove all accessories and packing materials from the top section of the shipping box.
2. Remove the cardboard cover.

CAUTION: The microtome is bolted to a wooden shipping platform contained within the shipping box. Do not attempt to remove the microtome from the shipping box by grasping and lifting the microtome! Instead, carefully follow all of the steps of this procedure.

WARNING: THE MICROTOME AND ATTACHED PLATFORM ARE HEAVY. AT LEAST TWO PEOPLE ARE REQUIRED TO SAFELY LIFT THEM FROM THE SHIPPING BOX.

3. Grasping the two handles on the platform, carefully lift the platform, with the attached microtome, out of the shipping box, placing it gently onto an appropriate load-bearing work surface.
4. Remove the protective plastic shipping cover.

CAUTION: Two people are required to unbolt the microtome from the platform.

5. Carefully tilt the microtome with attached platform so that the microtome is resting on its back. This exposes the underside of the platform and allows access to the shipping bolt. If desired, cushion the microtome with towels, gauze, plastic shipping cover, etc. to protect the microtome from being scratched.
6. With one person holding the microtome stable, a second person (using an 8 mm Allen wrench) removes the shipping bolt, releasing the microtome from the platform.
7. After removing the platform, carefully tip the microtome upright.
8. The microtome can now be placed on a stable counter for use. When moving the microtome, grasp it by its base.

Refer to Page 14 for installation of blade holder and blade holder base.

Installation Site Requirements

The installation site needs to fulfill the following requirements:

- Stable laboratory bench with minimal vibration
- Vibration-free floor recommended
- Easy and convenient access to the sectioning handwheel and the coarse feed wheel
- Ambient temperature always between +10 °C and +40 °C (°F to +104 °F)

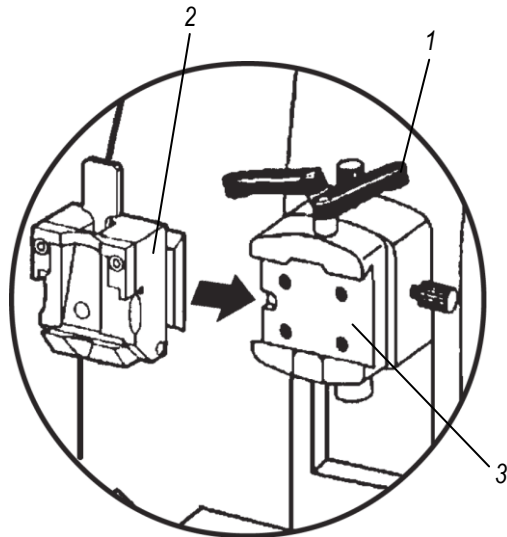

Fig. 3-1

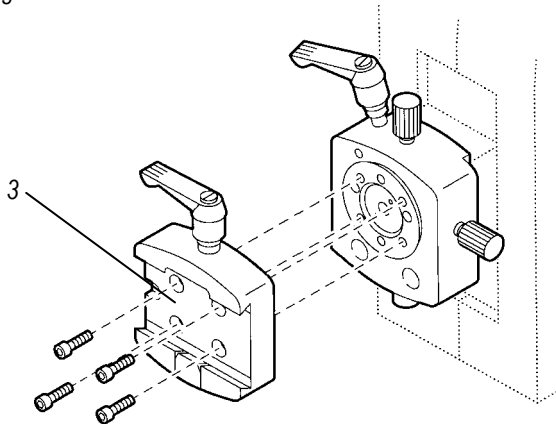

Fig. 3-2

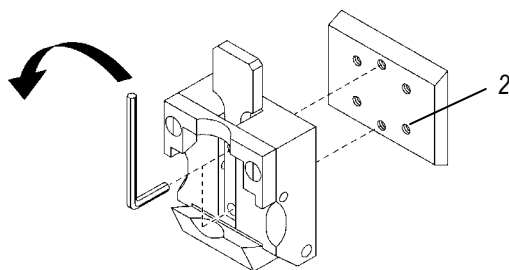

Fig. 3-3

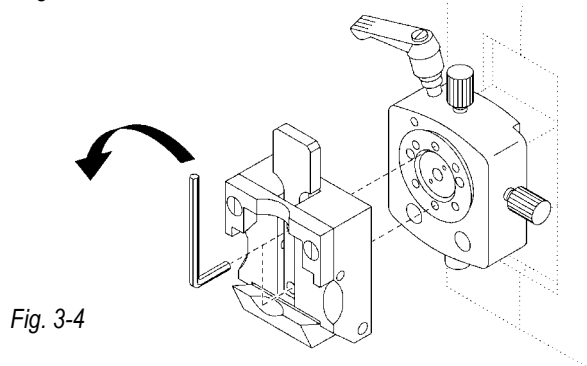

Fig. 3-4

Inserting the Specimen Clamp

The Accu-Cut® SRM™ 200 standard accessories include one orientation attachment for clamps (product code 1438) and one universal cassette clamp (product code 1439). The orienting clamp attachment with adapter allows for three-axis orientation of the specimen without having to release the specimen clamp.

A fixed attachment for clamps (product code 1443) is available as an option. Both attachments are compatible with all three specimen clamps available for the SRM 200 (universal cassette clamp, specimen clamp 40 x 40, specimen clamp 50 x 55.) See Section 4, Using the Accessories, for a complete description.

Refer to Fig. 3-1 on inserting the specimen clamp.

- Rotate the handwheel to move the attachment for specimen clamps to the uppermost position and lock the handwheel.
- To release the clamp, rotate the clamping lever (1) counterclockwise (Fig. 3-1).
NOTE: The clamping lever is spring loaded. If you need to adjust it, lift it slightly and reposition.
- Insert the dovetail guide (2) of the specimen clamp from the left into the dovetail clamp (3).
- Retighten the clamping lever (1) by rotating it clockwise.

Direct Fitting of the Specimen Clamp onto the Orientation Attachment



The specimen clamps (standard specimen clamp or universal cassette clamp) can also be directly fastened onto the orientation attachments.

- Use the handwheel to rotate the attachment to the uppermost position and lock the handwheel.
- To remove the clamp adapter (3) from the orientation attachment (Fig. 3-2), detach the four screws with a size 3 Allen key.
- To remove the dovetail guide (2), detach the two corresponding screws at the specimen clamp (Fig. 3-3).
- Place the specimen clamp onto the orientation attachment as shown in Fig. 3-4 and secure it with two corresponding screws.

OPERATING INSTRUCTIONS

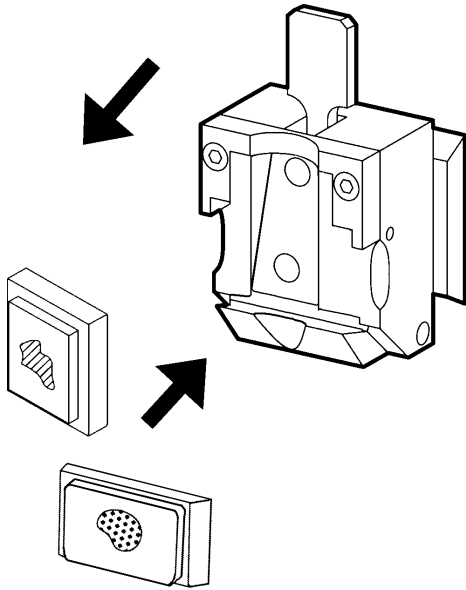

Fig. 3-5

Inserting the Specimen Block



Always lock the handwheel and cover the cutting edge with the blade guard prior to manipulating the blade and specimen, changing the specimen, or when the instrument is not in use.

- Rotate the handwheel to place the specimen clamp in the uppermost position.
- Lock the handle into place to secure the handwheel.
- Insert the specimen block into the specimen clamp.



Refer to Section 4, page 21, Using the Accessories, for details on how to insert specimens and a thorough description of each of the different types of specimen clamps.

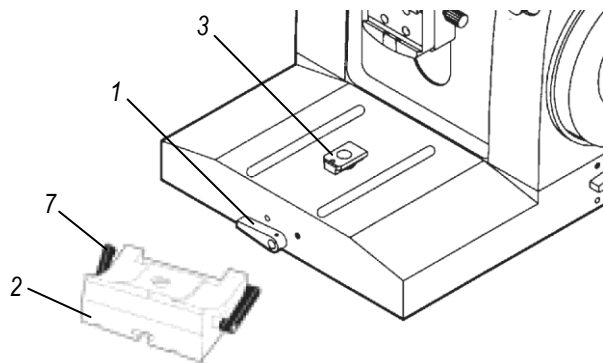

Fig. 3-6

Mounting the Blade Holder Base Assembly

- Secure the clamp for lateral displacement (7).
- Release the clamping lever (1) by rotating it counterclockwise (position ○ = released).
- Place the blade holder base assembly (2) onto the “T” piece (3) located on the microtome base plate.
- Lock the clamping lever (1) by rotating it clockwise (position ● = locked).
- Verify that the blade holder base is locked in place.

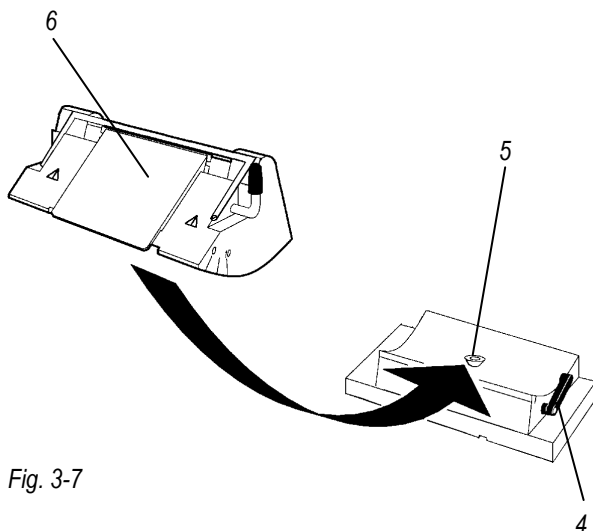

Fig. 3-7

Mounting the Holder for Disposable Blades

- Release the clamping lever (4) by rotating it counterclockwise.
- Place the blade holder for disposable blades (6) onto the “T” piece (5) of the blade holder base assembly.
- Lock the clamping lever (4) by rotating it clockwise.
- Verify that the blade holder is locked in place.

Inserting Disposable Blades



Be very careful when handling microtome blades. Their cutting edge is extremely sharp and can cause severe injuries!



For a detailed description on how to insert disposable blades, please refer to Section 4, pages 23 and 25, Using the Accessories.

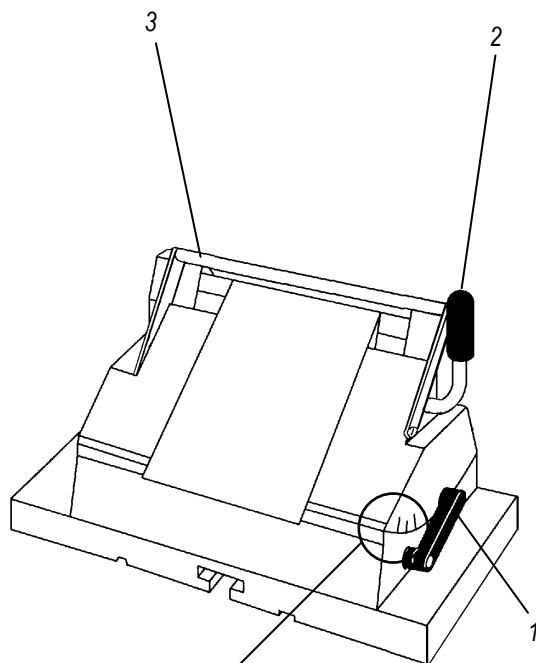

Fig. 3-8

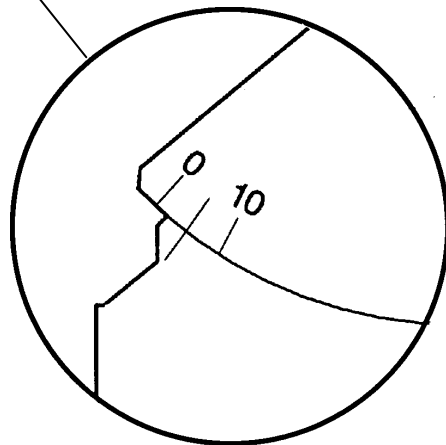

Fig. 3-9

- Carefully insert the disposable blade into the blade holder and secure it by rotating the clamping lever clockwise (2).
- Position the blade guard in the upright position (3) to protect the operator.

Adjusting the Clearance Angle

The scale (0°, 5°, 10°) for the adjustment of the clearance angle is located on the right side of the blade holder (1).

On the right side of the blade holder base, there is an index line which serves as a reference point for the adjustment scale. (Refer to Fig. 3-8).

- To release the clamping mechanism, rotate the lever (1) counterclockwise.
- Adjust the blade holder so that the index line of the desired clearance angle coincides with the reference line on the blade holder base.
- Hold the blade holder in the desired position and rotate the lever (1) clockwise to secure it.

OPERATING INSTRUCTIONS

Orienting the Specimen

The orienting clamp attachment facilitates three-axis specimen orientation without having to release the specimen clamp (7).

- Rotate the handwheel to move the specimen to the uppermost position and lock the handwheel.
- Cover the blade with the blade guard.
- Rotate the coarse feed wheel counterclockwise to move the specimen away from the blade edge to the maximum traveling position. (See Page 17, The coarse feed wheel).



Never orient a specimen during the retraction phase as the specimen will advance by the retraction value plus the selected section thickness! Due to that fact, there is a risk that both specimen and cutting edge may be damaged!

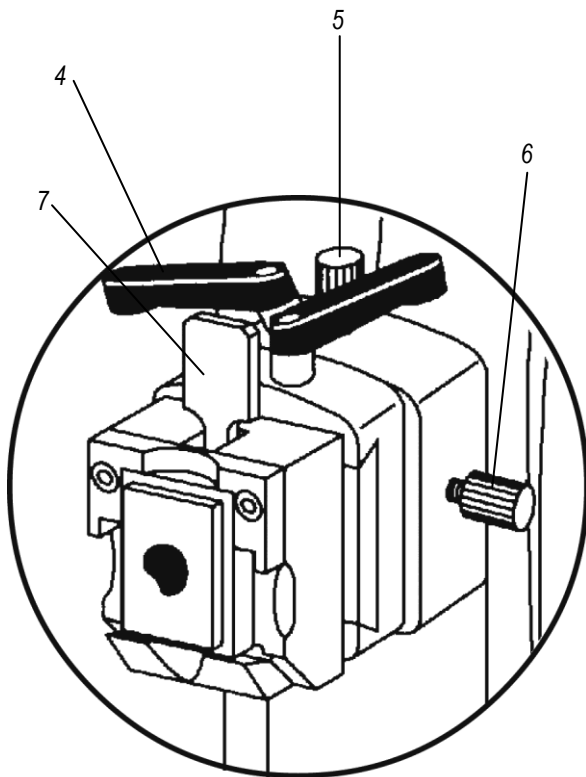

Fig. 3-10

- To release the clamping mechanism, rotate the clamp (4) counterclockwise.
- Use adjusting screw (5) to orient the specimen in the vertical direction, and adjusting screw (6) to orient in the horizontal direction.
- To secure the specimen in the adjusted position, rotate the clamp (4) clockwise.
- Release the clamping lever at the front of the microtome base and move the blade holder base assembly to a position close to the specimen. (See Page 22, Repositioning the blade holder base.)



When working with the large-size standard specimen clamp (50 x 55 mm), the vertical direction orientation of 8° cannot be fully utilized. The usable clearance angle, in that case only, is approximately 4°.

Specimen Trimming with the Coarse Feed Wheel

The coarse feed wheel

The coarse feed wheel is positioned on the left side of the instrument (**Fig. 3-11**). When rotated, it advances and retracts the specimen.

The coarse feed advances the specimen during clockwise rotation. The direction of rotation is indicated by an arrow shown in Figure 3-10. When rotating the coarse feed wheel in the direction of the arrow, the specimen moves toward the blade.

The coarse feed is used for rapid horizontal movement of the specimen, both forward (towards the blade) and backward (away from the blade).

After having reached the rear or front limit of the instrument respectively, the coarse feed wheel can only be rotated with considerable effort. In addition, once the front limit is reached, the specimen will stop advancing.

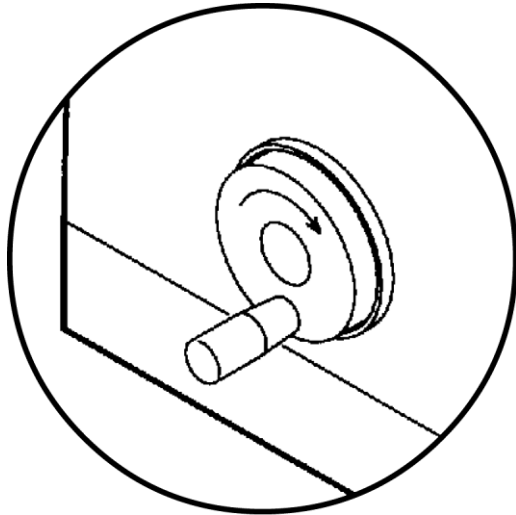

Fig. 3-11

Trimming the specimen

- Unlock the handwheel.
- Rotate the coarse feed wheel in a clockwise direction to gradually bring the specimen closer to the blade while simultaneously rotating, not rocking, the sectioning handwheel. Keep trimming until you reach the desired area of the specimen where you wish to begin sectioning.
- The handwheel should be rotated in complete revolutions when trimming the specimen block.
- Release the trimming lever before the handle of the handwheel reaches the 9 o'clock position during its clockwise rotation.

Trimming the specimen using the section thickness setting

- Using the section thickness adjusting knob (1) located on the upper right corner of the microtome, you may choose a thick setting to begin trimming (e.g. 50 μm). The selected thickness appears in the section thickness indicator (2). With each rotation of the handwheel, the specimen will advance the selected micron setting.

NOTE: "Rocking" the handwheel is not recommended.

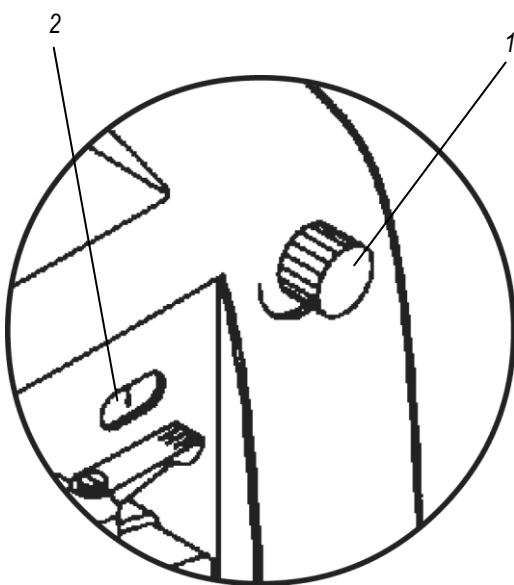

Fig. 3-12

OPERATING INSTRUCTIONS

Trimming with the Mechanical Trimming Lever

The Accu-Cut® SRM™ 200 is equipped with a mechanical trimming function which is activated by a trimming lever. The trimming lever has 2 settings: 10 μm and 50 μm . The settings are marked as follows:

- = 10 μm
- ● = 50 μm

In the default position or uppermost position, the lever is at the 0 μm position. The specimen advance is then controlled by the section thickness setting.

To select the 10 μm trimming advance, press the lever to the area marked (●) and hold it there. Every rotation of the handwheel will advance the specimen 10 μm .

To select the 50 μm trimming advance, press the lever down to the bottom position (● ●) and hold it there. With every turn of the handwheel, a specimen advance of 50 μm takes place. If the section thickness setting value is more than 10 or 50 μm respectively, it will override the trimming function.

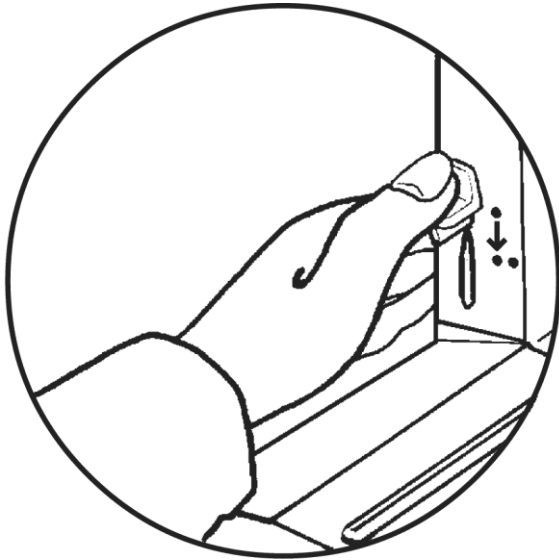

Fig. 3-13

NOTE: If the trimming lever is released **before** the handle of the handwheel reaches the 9 o'clock position, the trimming function disengages. The next rotation will then return to sectioning at the displayed section thickness setting.

If the trimming lever is released **after** the handle of the handwheel has passed the 9 o'clock position, the specimen will be sectioned at the trimming setting, not the micron setting.

The next rotation will then return to sectioning at the displayed section thickness setting.



The selected trimming value, 10 μm or 50 μm , will always override the section thickness setting unless the section thickness setting is greater.

To trim the specimen with the mechanical trimming lever:

- Rotate the coarse feed wheel to move the specimen close to the blade.
- Select the desired trimming value.
- Trim the specimen by rotating the sectioning handwheel until reaching the desired level for sectioning.
- Release the trimming lever and begin sectioning.

NOTE: "Rocking" the handwheel is not recommended.



The trimming lever should not be removed. If the trimming lever is accidentally removed, replace it carefully by making sure that the metal shaft inside the case is positioned between the two pins on the lever.

Sectioning



Always rotate the handwheel evenly. Always work at a rotation speed which is appropriate for the hardness of the specimen, i.e. the harder the specimen, the slower the speed of rotation.

- Select the desired section thickness with the thickness adjustment knob or check the indicator to see if it suits your purposes.
- For sectioning, you may want to use an area of the blade other than the one you used for trimming. You can use the lateral displacement feature on the SRM 200 to reposition the blade.
- To section, rotate the handwheel clockwise.

Inserting and Removing Specimens



Always lock the handwheel and cover the cutting edge with the blade guard prior to manipulating the blade and specimen, changing the specimen, or when the instrument is not in use.

- Rotate the handwheel to bring the specimen to the uppermost position and lock the handwheel.
- Cover the cutting edge with the blade guard.
- Remove the specimen from the specimen clamp and insert a new specimen.

End of Day Protocol

- Rotate the handwheel to bring the specimen to the uppermost position and lock the handwheel.
-



Be very careful when handling microtome knives or disposable blades. Their cutting edge is extremely sharp and can cause severe injuries!

Never place a knife on any surface with the cutting edge facing upwards!

Never leave blades lying around without protection! While not in use, always store knives in their cases! Never try to catch a falling blade!

- Remove the blade from the holder and dispose of it properly. When working with a reusable, steel knife, store the knife in its corresponding case after cleaning.
- Remove the specimen from the specimen clamp.
- Pick up any section waste.
- Clean the instrument (see Section 6, Care of Instrument).

Specimen Clamps and Inserts



All specimen clamps can be used in combination with both the orienting and fixed clamp attachments.

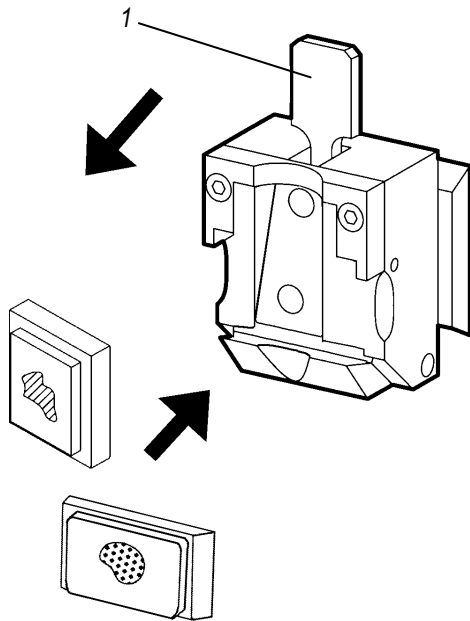

Fig. 4-1

Universal cassette clamp

The universal cassette clamp is designed for horizontal or vertical clamping of all kinds of commercial cassettes.

- Pull the lever (1) forward as shown in the diagram.
- Mount the cassette horizontally or vertically as required.
- Release the lever (1) to secure the cassette in position.

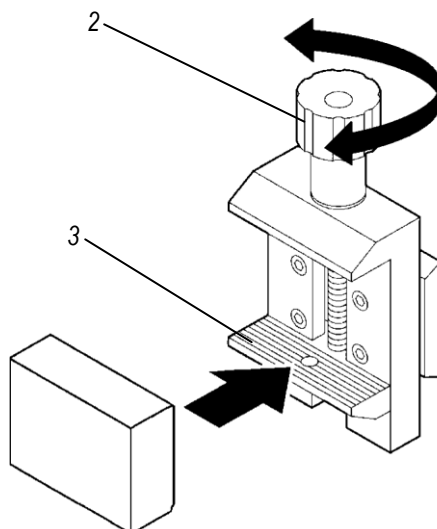

Fig. 4-2

Standard specimen clamps (optional)

The standard specimen clamp is available in two sizes: 40 x 40 mm and 50 x 55 mm. It is designed for direct clamping of rectangular blocks. In addition, it accommodates foil clamps.

- Turn the knob (2) counterclockwise to move the movable jaw (3) downward.
- Mount the sample as required.
- Turn the knob (2) clockwise to move the jaw (3) upward against the fixed jaw to securely clamp the specimen block.

A V-insert (#1446) is an optional accessory which is used in conjunction with the standard clamp (40 x 40 mm or 50 x 55 mm). The V-insert is used to clamp round-shaped specimen holders.

USING THE ACCESSORIES

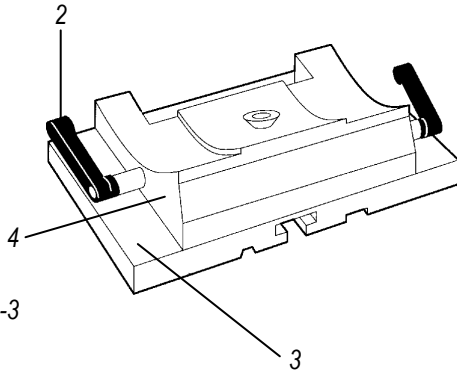

Fig. 4-3

Blade Holder Base Assembly (Fig. 4-3)



Install blade holder and blade holder base as shown in Fig. 4-4.

The blade holder base assembly with lateral displacement consists of two individual pieces and can be adjusted in a north-south direction (3) as well as laterally (in an east-west direction) (4).

Repositioning the blade holder base (Fig. 4-4)

North-South orientation (Vertical direction)

The north-south orientation is designed to bring the blade holder as close as possible to the specimen for an optimal sectioning position.

- Turn the clamping lever (1), at the front of the microtome base plate, counterclockwise to release the clamping mechanism.
- Move the blade holder base with attached blade holder forward or backward.
- Turn the lever (1) clockwise to tighten it.

East-West orientation (Horizontal direction)

The lateral displacement feature permits using the entire length of the cutting edge of the blade without having to release the blade clamping mechanism.

To move the blade holder base laterally:

- Turn the clamping lever (2) clockwise to release the clamping mechanism.
- Adjust the blade holder base to the desired position.
- Turn the lever (2) counterclockwise to secure the clamping mechanism.
- To separate the two holder base assembly pieces for cleaning, unlock the lateral orientation lever (2) in Fig. 4-3. Pull the lever to the left to remove. The blade holder (lateral) base will lift off the sub-base portion. To reassemble, place the blade holder base together and completely reinsert the locking lever. Lock into position.

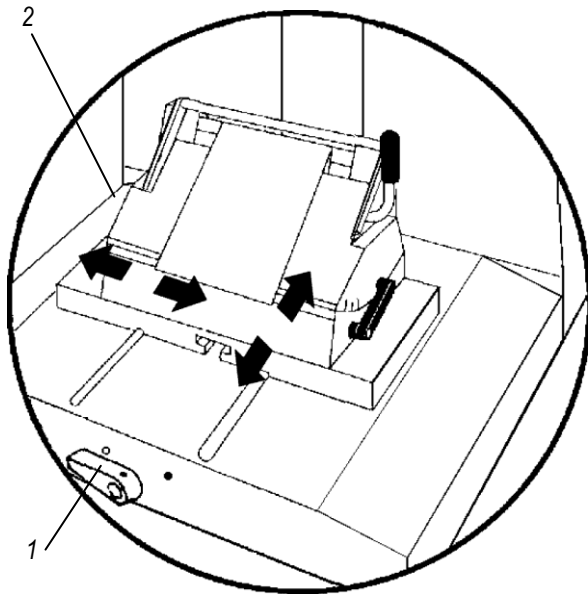

Fig. 4-4

Holder for Reusable Knives (Fig. 4-5)

The knife holder is designed for standard steel and tungsten carbide knives, profile c and d, up to 16 cm long. In addition, it is appropriate for various blade rails for disposable blades, which are inserted in the holder like a knife.

The knife can be repositioned in height. This enables the use of frequently resharpened knives.

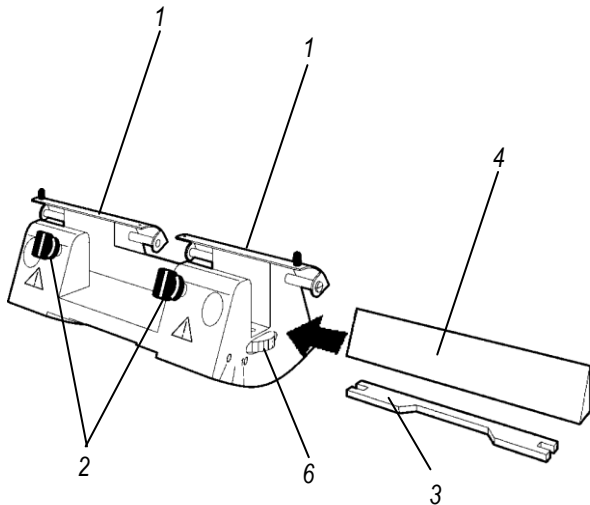

Fig. 4-5

Mounting the knife support bar

- Slide the knife guard (1) to the middle.
- Place the knife support bar (3) as shown on the height adjustment screws (not visible), ensuring that the flat top-ends of the height adjustment screws are seated in the slots at both ends of the knife support bar.

Inserting the knife

- Move the knife support bar via the height adjustment screws to the lowest position by turning the wheels (6) on the right and left of the knife holder in opposite directions to the front. This will prevent damage to the cutting edge while inserting the knife.
- Unscrew the knife clamping screws (2), turning counterclockwise, as far out as possible.
- Hold the knife (4) at the knife back and carefully insert it in the holder from the right side as shown with the cutting edge facing upward.

Adjusting the knife height (Fig. 4-6)

When adjusting the clearance angle, the cutting edge of the knife should be positioned in the center of rotation of the knife holder. The knife is correctly positioned in height when the cutting edge is level with the locating edge of the rear clamping jaws. The knife edge should be parallel with the locating edges (5).

- Turn the wheels (6) in opposite directions to the rear in order to position the knife edge parallel and level to the locating edge (Fig. 4-6) on the rear clamping jaws.
- To clamp the knife (4), tighten the two clamping screws (2) uniformly by turning them clockwise.

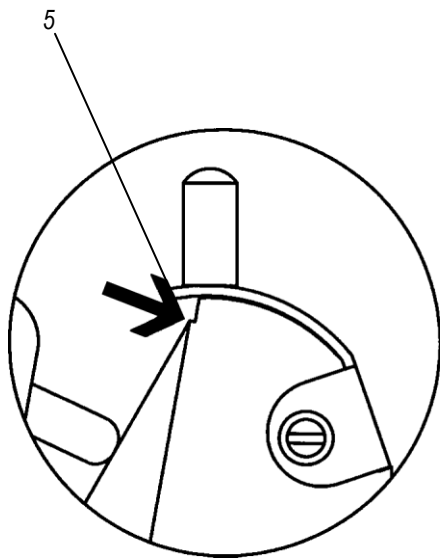

Fig. 4-6

Inserting the blade rails

The blade rails should be inserted in the knife holder and clamped.

USING THE ACCESSORIES

Holder for Disposable Blades

The SRM™200 is configured with a blade holder for use with low profile disposable blades or a holder configured for use with high profile disposable blades.

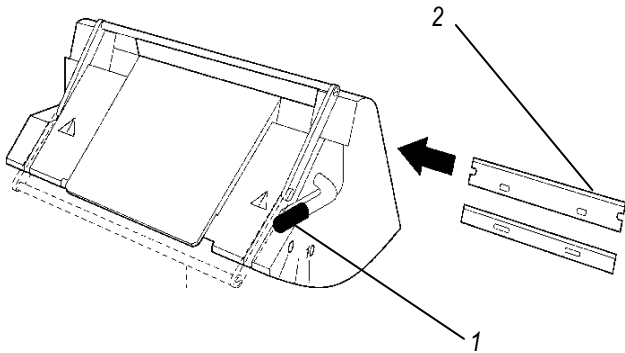

Fig. 4-7

Inserting the blade

- Verify that the blade holder base assembly levers are locked.
- To insert the blade, move the clamping lever **(1)** down.
- Carefully insert the blade **(2)** from the right side of the blade holder.
- To clamp the blade, move the clamping lever **(1)** up.

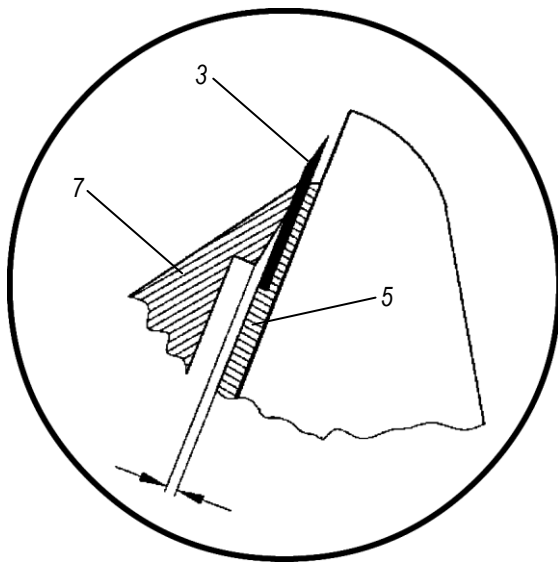

Fig. 4-8

Adjusting the Front Adapter Plate (Fig. 4-8)

- Place the front adapter plate (7) in its correct position, insert the clamping lever (2), and slightly fasten the adapter plate by tightening the clamping lever. Do not overtighten.

The screws (10) on the underside of the blade holder are used to adjust the height of the adapter plate.

- Adjust the height of the adapter plate (7) with screws (10). The upper edges of both adapter plates (5) and (7) need to be at the same height and parallel to each other.

The clearance angle of the adapter plate (7) is adjusted with screw (9) which can be accessed at a slant angle from behind, through an opening in the underside of the knife holder.

- Insert the blade with the cutting edge facing down in order to minimize the risk of injury, and fasten it slightly with the clamping lever (2).
- Adjust the adapter plate (7) with screw (9) in such a way that only the upper edge of the adapter plate actually exerts pressure on the blade. A visible gap must remain. When the adapter plate is clamped tightly, this gap will disappear.

Cleaning (Fig. 4-9)

The front adapter plate (7) can be removed for cleaning.

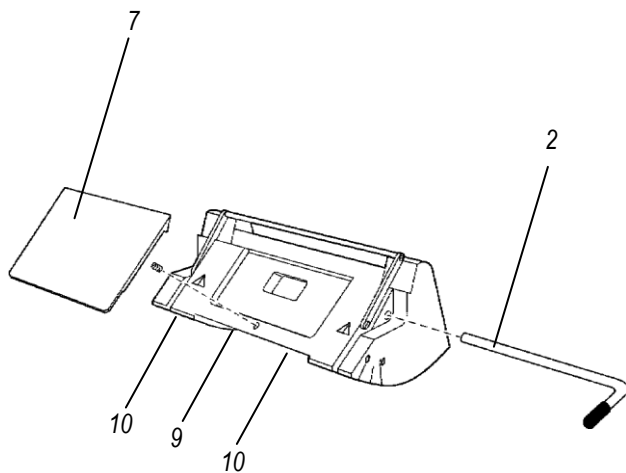

Fig. 4-9

- To remove the blade, move the clamping lever (2) down.
- Carefully remove the blade.
- Pull out the clamping lever (2).
- Remove the adapter plate (7).



**Use only mild commercial detergents or a soap solution for cleaning!
Do not use harsh solvents such as acetone.**

- Clean the blade holder with a damp cloth.
- Place the adapter plate back onto the blade holder (7), insert the clamping lever (2), and tighten.



**For Left-Handed Convenience:
The clamping lever (2) can also be inserted on the left side of the blade holder. This will, however, change the locking position of the lever. To unlock, move the lever upward; to clamp, move the lever downward.**

Cleaning



Remove the blade or knife and lock the hand-wheel before starting the cleaning process!

Avoid harsh solvents such as acetone which will damage the surface of the microtome and rubber/vinyl parts.

Make sure that no liquids get into the interior of the instrument while cleaning!

When using detergents, comply with the safety instructions of the manufacturer and with all applicable regulations in your laboratory.

- Lock the handwheel.
- Remove sectioning waste with a dry brush.
- Remove the blade holder and blade holder base for cleaning.
- Clean the instrument and accessories with a slightly moistened cloth.

Disposal

The instrument or parts of the instrument must be disposed of in compliance with local laws.

CARE OF THE INSTRUMENT

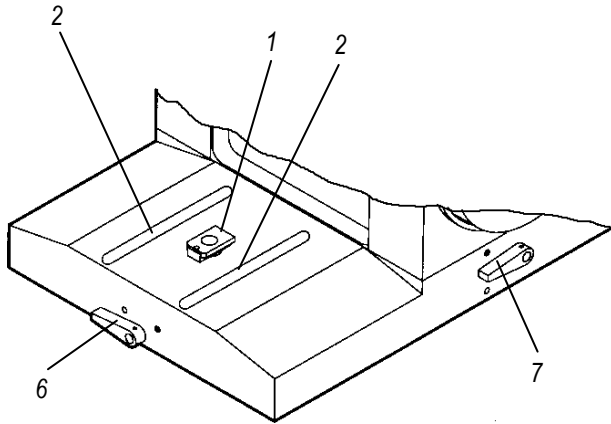

Fig. 6-1

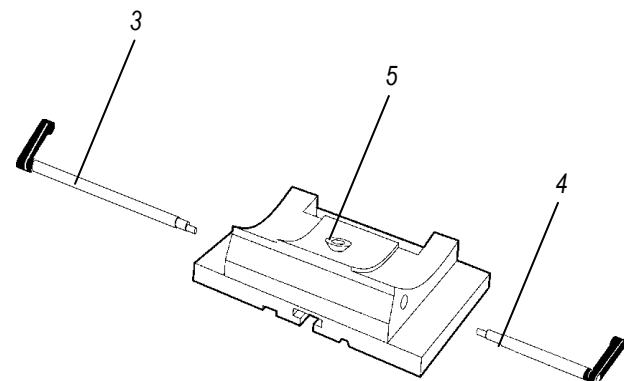

Fig. 6-2



The base assembly should be carefully guided onto the guide rails (Fig. 6-1, item 2) and secured by moving the clamping lever (6) to the right. Verify that the blade holder base is positioned so that the thick edge is facing away from the instrument as shown in Fig. 6-2.

Maintenance

Maintenance Checklist

- Clean the instrument daily.
- Lubricate the instrument monthly.
- Have the instrument inspected yearly by a qualified service technician authorized by Sakura Finetek.

Maintenance Procedures

This Accu-Cut® SRM™ 200 is virtually maintenance-free. To ensure smooth operation of the instrument we recommend the following:

- Remove debris and clean the instrument daily.
- Lubricate the following parts with 1 to 2 drops of oil No. 405 (Product Code 1447) once a month:
 - T piece (1) on the microtome base plate.
 - Guides (2) on the microtome base plate.
 - Clamping levers (3) and (4) on the right and left side of the blade holder base.
 - T piece (5) on the blade holder base.



When reassembling the blade holder base assembly (Fig. 6-2), be certain that the long clamping lever (3) is inserted into the opening on the left side of the base assembly and secured. The shorter clamping lever (4) should be inserted on the right side and secured.

- Use the (optional) Microtome Waste Collection System, product code 4657, to facilitate easy cleaning of the instrument. Replacement waste collection bags can be ordered using product code 4658.
- Do not carry out any repairs on your own as this will invalidate the warranty. Repairs may only be carried out by qualified service technicians authorized by Sakura Finetek.
- For information on service contracts, please contact your local Sakura Finetek dealer or contact Sakura Finetek directly.

Problems, Possible Causes, and Remedies

Problem	Possible Cause	Remedy
<p>Thick/thin sections. The section thickness varies from one section to another. In extreme cases, sections are skipped and a section is not obtained.</p>	<ul style="list-style-type: none"> - Insufficient knife/blade inclination; consequently the clearance angle is too small. - Insufficient clamping of specimen and/or blade. - Blunt knife/blade. 	<ul style="list-style-type: none"> - Systematically try several clearance angle adjustments, until the optimum angle is found. - Check that all levers are locked and screws are tightened on the specimen and blade holder system. Retighten the levers and screws if necessary. - Use a different part of the cutting edge or use a new knife/blade.
<p>Compressed sections. The sections are extremely compressed, wrinkled or jammed together.</p>	<ul style="list-style-type: none"> - Blunt knife/blade. - Specimen too warm. - Clearance angle too big. - Sectioning speed too fast. 	<ul style="list-style-type: none"> - Use a different part of the cutting edge or use a new knife/blade. - Cool the specimen on a cold plate. - Cool the specimen in iced water immediately before sectioning. - Clearance angle adjustment; systematically decrease the clearance angle until the optimum adjustment is obtained. - Rotate the handwheel at a slower speed.
<p>The blade “rings” on the cutting stroke when sectioning hard specimens. Sections show scratches and chatter marks.</p>	<ul style="list-style-type: none"> - Sectioning speed too fast. - Clearance angle too big. - Insufficient clamping of specimen and/or blade. 	<ul style="list-style-type: none"> - Rotate the handwheel at a slower speed. - Clearance angle adjustment; systematically decrease the clearance angle until the optimum adjustment is obtained. - Check that all levers are locked and screws are tightened on the specimen and blade holder system. Retighten the levers and screws if necessary.
<p>Specimens will not advance; no sections produced.</p>	<ul style="list-style-type: none"> - Specimen has reached the front feed limit. - The coarse feed wheel cannot rotate freely. 	<ul style="list-style-type: none"> - Turn the coarse feed wheel in the appropriate direction to move the specimen toward the rear limit. - Remove any obstruction.

Service Information

When problems arise during routine operation of the Accu-Cut® SRM™ 200 Rotary Microtome, first refer to Section 7, TROUBLESHOOTING. Avoid problems by carefully following proper operating and cleaning procedures. If a problem cannot be solved and an instrument failure is apparent, our Customer Support Department is available to assist you.

The instrument should be disinfected prior to being serviced.

Where to Call for Service

If located within the United States or Puerto Rico, contact the Customer Support Department of Sakura Finetek U.S.A., Inc. by calling:

1-800-725-8723

or

1-310-972-7800.

If located within Canada, contact Somagen Diagnostics by calling:

1-800-661-9993.

In countries other than the United States, Canada, or Puerto Rico, contact the nearest authorized SAKURA instrument distributor or representative for service information and assistance. For more information about your local distributor or representative outside of the U.S.A., Canada, or Puerto Rico contact Sakura Finetek Europe B.V. in the Netherlands by calling:

+31-88-59.20.032

or FAX

+31-88-59.20.001

When requesting a service call, please provide the following information:

- a. Model and serial number of the instrument
- b. Date of delivery
- c. Location of the instrument and the contact person
- d. The reason for the service call

Return Information

Sakura Finetek cannot accept goods returned without prior authorization.

If an instrument or any part is to be returned to Sakura Finetek, please note the following:

- a. Please contact Sakura Finetek directly to obtain a returned goods authorization number and for appropriate shipping instructions and procedures.
- b. If the instrument or any part of it has been exposed to or been in contact with potentially pathogenic or radioactive materials, it is essential to decontaminate the instrument or part. Decontamination must explicitly be confirmed by the customer. Our service technicians must inquire about this.
- c. Ensure that there is no radioactivity or hazardous bacteria present and advise Sakura Finetek of any decontamination procedure that may have been carried out.

Should the instrument or any part be received in a condition that Sakura Finetek considers to be a potential biological hazard, the instrument or part will be returned unrepared at the expense of the customer.

A

Accessories 6, 11
Adapter plate 23, 24

B

Blade guard 8, 15, 16, 19
Blade holder 8, 10, 14, 22, 23, 24
Blade holder base 22
Blade holder base assembly 14, 22
Blade rails 25
Brake lever for activating the handwheel brake 5

C

Clamp for adjusting blade angle 5
Clamp for blade holder base assembly 5
Clamp for lateral displacement 5
Clamp for securing blade 5
Clamping mechanism 22
Clamping plate 24
Cleaning 9, 24, 27, 28
Clearance angle 15
Coarse feed function 6
Coarse feed wheel 5, 16, 17, 18

D

Dimensions 10
Disposable blade 14, 15
Disposal 27

F

Fixed attachment for clamps 13

H

Handwheel 7, 8, 13, 14, 16, 17, 18, 19
Handwheel brake 7
Handwheel locking system 7
Holder for disposable blades 8
Holder for reusable knives 8, 25

I

Index line 15
Installation 9, 11

K

Knife guard 8, 25
Knife holder 8, 25

L

Lateral displacement 19, 22
Left-handed convenience 24

M

Maintenance 9, 28
Maintenance checklist 28
Maintenance procedures 28
Mechanical trimming function 6, 18
Micron thickness setting 18
Mounting the blade holder 14
Mounting the blade holder base assembly 14
Moving the instrument 11

O

Orientation screw 5
Orientation attachment for clamps 13, 16

P

PARAMETERS 10
Platform base 11

R

Repairs 4, 28
Return information 31

S

Safety device 7
Safety instructions 7
Section thickness 6, 19
Section thickness adjusting knob 17
Section thickness control knob 5
Sectioning 6, 19
Service 31
Service contacts 28
Service information 31
SPECIFICATIONS 10

Specimen block 14
Specimen clamp 13
Specimen retraction 6
Specimen trimming 17
Standard specimen clamp 16, 21

T

Temperature 10
Thickness adjustment knob 19
Transport 9
Trimming lever 5, 18
TROUBLESHOOTING 29

U

Universal cassette clamp 13, 21
Unpacking 11

W

Warranty registration card 4
Weight 10